

# UTILITY SERVICE ENTRANCE STANDARDS



# UTILITY SERVICE ENTRANCE STANDARDS

## Table of Contents

0. Scope .....	1
1. Definitions .....	1
2. Deviations From The Standard .....	3
3. The Canadian Electrical Code .....	3
4. Interference With Utility Equipment .....	4
5. Requirements For Service .....	4
6. Supply Voltages .....	4
7. Utility Owned Transformers .....	6
8. Load Balance .....	6
9. Electric Loads .....	6
10. Service Capacity .....	8
11. Service To Multiple Occupancy Buildings .....	8
12. Service Entrances .....	10
13. Customer Service Conductors .....	17
14. Customer Service Equipment .....	19
15. Canadian Electrical Code Rules Regarding Service Entrances.....	20
16. Metering .....	23
17. Metering Specification For Customer Owned Switchgear .....	31

## Figures

- Fig. 1 Service Mast Extending Through Roof
- Fig. 2 Service Point of Attachment on Wall
- Fig. 3 Pre-Wired, Single Phase, 120/240 Volt, 201 to 600 Amp, Current Transformer Connected Enclosure
- Fig. 4 Single Phase, 120/240 Volt, 201 to 600 Amp, Current Transformer Connected
- Fig. 5 Three Phase, 120/208 or 347/600 Volt 201 to 1200 Amp
- Fig. 6 Current Transformer Connected May Pole, 120/240V 400 Amp
- Fig. 7 Self-Contained May Pole, 120/240V to 200 Amp
- Fig. 8 Customer Owned Pole for Non-Fixed Premise
- Fig. 9 Temporary Service Entrance, Tripod Mounted
- Fig. 10 Outdoor Metering
- Fig. 11 Utility Metering Equipment - Summary
- Fig. 12 Installation of Metering Current Transformers
- Fig. 13 Municipal Festive Lighting

# UTILITY SERVICE ENTRANCE STANDARDS

## 0. SCOPE

This standard sets forth the minimum utility requirements for electrical service in the province of New Brunswick. It is not to be regarded as a design specification and is not all inclusive with respect to the installation of electrical equipment or wiring.

The requirements of this standard are in addition to the requirements of the latest adopted Canadian Electrical Code and the provincial electrical inspection authority, NB Department of Public Safety, Technical Inspection Services.

## 1. DEFINITIONS

### **Complex Structure:**

A complex structure is any structure that would be difficult to supply with a single service entrance due to its physical characteristics or electrical requirements. The designation of a structure as 'complex' must be mutually agreed upon by the Supply and Inspection authorities.

### **Customer:**

A Customer is defined as the owner, occupant, or an agent of the owner or occupant of a building or occupancy who deals with the Supply Authority regarding the service entrance to the building or occupancy. A Customer's agent may include electricians, contractors, consultants, engineers or trustees of any kind.

### **Customer's Service Conductors:**

This term refers to Customer owned conductors. On an overhead entrance these would typically be the conductors in the service conduit from the point at which the Supply Authority makes connection at the service head to the Customer's first service enclosure. On an underground entrance these would be the underground cables from the utilities secondary system or transformer to the Customer's first service enclosure.

### **Firewall/Fire separation:**

Where occupancies of a building are separated by a firewall or a fire separation, the occupancies shall be considered as separate buildings for the purpose of electrical service. Firewalls and fire separations must be constructed in compliance with the National Building Code and confirmed as such in writing by a recognized building inspector, architect, professional engineer, or fire marshal.

**Non-fixed Premise:**

Non-fixed premise typically refers to a premise that is not a permanently placed structure, such as a travel trailer or motor home. See section 12.5 for service entrance options.

**Service Box:**

An approved assembly consisting of a metal box or cabinet constructed so that it may be locked or sealed, containing either service fuses and a service switch or a circuit breaker, and of such design that either the switch or circuit breaker may be manually operated when the box is closed.

**Set of Utility Supply Conductors:**

This means a single or parallel run of “Triplex or Quadrex” to one service entrance.

**Supply Authority:**

The utility having the authority to supply electrical energy. New Brunswick has four Supply Authorities, NB Power, Saint John Energy, Edmundston Energy and Perth Andover Light Commission.

**Utility Approval:**

Written approval from the Supply Authority authorizing deviations from this standard. Utility Approval must be obtained prior to commencement of the work for which the Utility Approval is being requested and the authorized deviation will apply only to the specific installation for which it was granted.

**Utility Supply Conductors:**

This term refers to the utility owned overhead conductors connecting the Customer’s service conductors to the utility’s secondary system or transformer.

## **2. DEVIATIONS FROM THE STANDARD**

Where provisions are made for deviations from this standard, Utility Approval shall be required.

## **3. THE CANADIAN ELECTRICAL CODE**

Interpretation of the Canadian Electrical Code in the province of New Brunswick is the responsibility of NB Department of Public Safety, Technical Inspection Services.

The Utility Service Entrance Standard contains references to the Canadian Electrical Code which are of interest to the Supply Authority. This document does not, however, constitute a complete explanation of all CE Code rules, which apply to service entrances.

Where the code refers to compliance with the requirements of the local Supply Authority, the utility shall be consulted for approval. Where compliance is not met, the Supply Authority will request action by the Inspection Authority.

See also section 15 - Canadian Electrical Code Rules Regarding Service Entrances.

## **4. INTERFERENCE WITH UTILITY EQUIPMENT**

The Supply Authority does not permit disconnection or removal of meters, meter seals, utility supply conductors or any of its equipment. Requests for disconnection or removal of utility equipment shall be made to the utility's regional office.

## **5. REQUIREMENTS FOR SERVICE**

Service entrances will be connected upon compliance with the following requirements:

- a) the Supply Authority has approved the service entrance location, capacity and provisions for metering equipment; and
- b) the installation has a signed valid wiring permit or electronic authorization issued by NB Public Safety, Technical Inspection Services; and
- c) the master I.D. sticker, or the sub I.D. sticker, is affixed to the meter box(es); and
- d) the installation meets all other requirements of the Utility Service Entrance Standards.
- e) For all entrances larger than 200A, the electrical contractor must supply the Utility with a drawing showing the physical layout of the service entrance equipment including main disconnect, meter socket, instrument transformer cabinet, splitters, sub-metering, etc.
- f) Notwithstanding b) and c), work on Federal Land will require a signed letter from the electrical contractor confirming the electrical installation was completed in accordance with the CE Code.

## **6. SUPPLY VOLTAGES**

An electrical service should be designed such that the supply voltage is the voltage utilized by the largest portion of the load. The Customer shall supply all transformation necessary to serve loads utilizing voltages different from the supply voltage.

The frequency of all supply voltages is 60 hertz.

### **6.1 Primary Supply Voltages**

Contact the local supply authority for the requirements associated with service at primary voltages.

### **6.2 Secondary Supply Voltages**

Nominal secondary supply voltages are:

- a) 120/240 volt, single phase, three wire; or
- b) 120/208 volt, three phase, four wire grounded wye; or
- c) 347/600 volt, three phase, four wire grounded wye; or
- d) where Utility Approval is granted, 347/600 volt, three phase, four wire high resistance grounded wye. Where this configuration is approved and conforms to CE Code rules 6-412 and 10-1100 to 1108, the Customer shall provide the grounding resistor, all wiring, connectors, compartments, etc., associated with the high resistance ground installation.

### **6.3 Supply Voltage Operating Ranges**

The normal and extreme operating ranges for secondary supply voltages at the point of delivery, as per CSA standard C235, are as follows:

Nominal voltage - 120/240 Volts  
Normal Range - 110/220 - 125/250  
Extreme Range - 106/212 - 127/254

Nominal voltage - 120/208 Volts  
Normal Range - 112/194 - 125/216  
Extreme Range - 110/190 - 127/220

Nominal voltage - 347/600 Volts  
Normal Range - 318/550 - 360/625  
Extreme Range - 306/530 - 367/635

Improvement of voltage levels beyond the normal range but within the extreme range is done on a planned basis. Immediate corrective action shall be taken to correct voltage levels outside the extreme range.

## **7. UTILITY OWNED TRANSFORMERS**

Sizing of utility owned transformers is the responsibility of the utility. Customers shall not request transformers of a specific size.

## **8. LOAD BALANCE**

Services shall be designed such that the rated amperage and operating cycles of connected single phase loads will result in equal current in all phases of the supply. Under nominal operating conditions the actual current in all phases of the supply shall be within 10 percent.

## **9. ELECTRIC LOADS**

Operating large loads such as motors, electric furnaces, electric welders, air conditioners, heat pumps, etc., can produce momentary voltage sag or 'flicker'. It is the responsibility of the Customer to ensure that electric loads are switched on in such way that sag or flicker is minimized. The operating requirements of large loads should be given consideration during design of the service entrance.

### **9.1 Electronic Equipment**

The Customer is responsible for the installation of surge protection on sensitive electronic equipment.

### **9.2 Electric Motors**

#### **9.2.1 Motor Sizes:**

- a) The maximum motor sizes permitted for starting across the line shall be:
  - i) Single phase, 7.5 horsepower; and
  - ii) Three phase 120/208 volt, 15 horsepower; and
  - iii) Three phase 347/600 volt, 40 horsepower.
  
- b) Larger motors are permitted where:
  - i) The Customer installs some type of reduced voltage or variable frequency start for motors up to 90 HP; or
  - ii) Utility Approval is obtained, upon examination of the utility's system capabilities and the motor's characteristics



### 9.2.2 Motor Protection:

The Customer shall be responsible to provide all motor protection as per CE Code section 28.

Normal overload protection will likely not provide adequate protection during loss of one supply phase. Loss of one phase of the utility supply (or of the building distribution system) will cause overheating and damage to three phase motors. Therefore, protection against the loss of one supply phase is required and is the responsibility of the Customer.

### 9.2.3 Heat Pumps:

The Supply Authorities recommend heat pumps be fitted with starting capacitors.

## 10. SERVICE CAPACITY

### 10.1 Single Phase

- a) The maximum single phase service entrance capacity shall be 600 amps.
- b) Notwithstanding a), an 800 amp single phase underground service may be permitted with Utility Approval. [Utility Approval Criteria - Three phase service is not readily available from the utility and the utility's system capacity is adequate or, at the discretion of the utility.]

### 10.2 Three Phase

- a) The maximum overhead three phase service entrance capacity shall be 600 amps at 120/208V and 400 amps at 347/600V.
- b) For underground services terminating at a utility pole, the maximum number of runs will be limited to 2, not exceeding 1000MCM. 3 runs may be allowed with Utility Approval.
- c) The maximum three phase service entrance capacity shall be 2000 amps, not exceeding 8 runs of 1000MCM.
- d) Service entrances greater than 2000 amps may be permitted with Utility Approval. A detailed engineering analysis prepared by a registered professional engineer shall be submitted to the Inspection Authority. The design must also be approved by the Supply Authority.

## 11. SERVICE TO MULTIPLE OCCUPANCY BUILDINGS

- a) Multiple Occupancy Buildings include strip malls or plazas, duplex, row and semi-detached housing, and other such structures.
- b) Where a non-residential multiple occupancy building qualifies as complex structure, refer to section 15.1 Rule 6-102 - Number Of Supply Services Permitted.
- c) Where more than one set of utility supply conductors is run to a residential multiple occupancy building:
  - i) The services shall be run underground; and
  - ii) The occupancies shall be completely self-contained (i.e. no indoor access between occupancies); and
  - iii) The occupancies shall not be located one above the other; and
  - iv) The occupancies shall have a separate entrance with direct access to ground level.
- d) Notwithstanding c) i), multiple customer service entrances may be permitted overhead with Utility Approval. Where multiple overhead services are permitted the meters and service heads need not be grouped.

### **Intent:**

Utility Approval for multiple overhead supply services to residential multiple occupancy buildings shall only be given where:

- a) It will not cause the utility construction or operational problems (pole space, unacceptable mid-span taps); and
- b) It will not create undesirable aesthetics for surrounding Customers; and
- c) A municipal by-law does not restrict service to underground.

## 12. SERVICE ENTRANCES

### 12.1 Service Entrance Locations

#### 12.1.1 General:

Before commencing any service entrance installation, the Customer shall obtain approval from the Supply Authority for the route of the utility supply conductors, the location of the service head and the location of the point of attachment for the utility supply conductors as per CE Code rule 6-116 paragraph (a) and (b).

Where an approved service route crosses private property the Customer shall be responsible for supplying and clearing the route.

The Customer is responsible for any costs incurred by the utility in acquiring easements.

For all entrances larger than 200A, the electrical contractor must supply the Utility with a drawing showing the physical layout of the service entrance equipment including main disconnect, meter socket, instrument transformer cabinet, splitters, sub-metering, etc.

#### 12.1.2 Prefabricated Homes:

- a) As with buildings constructed on site, the Customer shall obtain approval from the Supply Authority for the route of the utility supply conductors, the location of the service head and the location of the point of attachment for the utility supply conductors for prefabricated homes (modular homes, mini homes, etc.) being constructed for a specific building lot.
- b) Where the entrance on a new prefabricated home will be stubbed out beneath the floor and conduit will be run to one side of the home for connection to a service mast, the Customer shall also obtain approval for the entrance location from the Supply Authority.

#### 12.1.3 Utility Supply Conductor Loop Lengths:

The maximum length of a utility service loop from the last utility pole to the point of attachment at the building shall be as follows:

Entrance Capacity	Maximum Loop Length	
	Single Phase	Three Phase
100A	30 m	27 m
200A	27 m	24 m
400A	18 m	18 m
600A	15 m	15 m

## 12.2 Overhead

### 12.2.1 Utility Supply Conductors - Point Of Attachment At Building (Figures 1 and 2):

- a) As per CE Code rule 6-112, subrule (1), a means of attachment shall be provided for the utility supply conductors. Utility supplied point of attachment hardware, or an equivalent, shall be installed by the Customer. As per CE Code rule 6-116, paragraph (a) and (b), the service head, and therefore the point of attachment, shall be installed in compliance with the requirements of the Supply Authority.
- b) As specified in CE Code rule 6-116, paragraph (b), the point of attachment shall be at a minimum of 150mm and a maximum of 300mm below where the Customer's service conductors emerge from the service head.
- c) The point of attachment shall be within 600mm horizontally from the service head and be on the same side of the building as the service head.
- d) The point of attachment shall maintain a clearance of 1.0 metre from windows, doors and porches.
- e) The point of attachment shall not exceed 6 metres above finished grade without Utility Approval and in no case shall it exceed 9 metres.
- f) Utility supply conductors above finished grade shall satisfy CE Code rule 6-112, subrule (3).
- g) In keeping with the Code requirement that the entrance be located in compliance with the requirements of the Supply Authority, the point of attachment shall not be located where the utility supply conductors are subject to physical damage.
- h) The point of attachment may be located on:
  - i) A service mast extending through a roof overhang (Figure 1); or
  - ii) The gable end (Figure 2); or
  - iii) Under eaves, provided the roof is not metal and the ground clearances of CE Code rule 6-112, subrule (3) can be met.
- i) A service mast passing through a roof overhang shall:
  - i) be located such that the distance the utility supply conductors cross over the roof does not exceed 2.0 metres in any direction. Where the distance would exceed 2.0 metres, consult the Supply Authority for approval. (Rationale: Supply service conductors crossing roofs create potential trip hazards for firefighters and snow removal crews.);
  - ii) be guyed to a main structural member of the roof (rafter, truss) where the point of attachment on the mast exceeds 1.5 metres above the roof (as per CE Code rule 6-112 (9)).

- j) The point of attachment shall be able to withstand a tension of 600 lbs. (2670 N).
- k) The point of attachment shall be such that it allows the utility to maintain a design clearance of 1.0m horizontal or 3.0m vertical between the utility supply conductors and building surfaces that are readily accessible.

#### 12.2.2 Customer's Service Stacks and Conduits:

- a) The maximum number of service stacks shall not exceed two. Two parallel conduits will be considered as one service stack.
- b) Service heads shall be located within 300mm of each other for connection; to a single set of utility supply conductors.
- c) Service conduit shall meet the requirements of the inspection authority and CE Code rule 6-112, subrules (4) and (5). However, where the point of attachment is on the service conduit, the conduit shall be rigid steel of a minimum nominal size of 2-1/2 inches.

#### 12.2.3 Customers Service Conductors at Service Head:

- a) As per CE Code rule 6-302, subrule (3), the Customer's service conductors shall extend a minimum of 750mm beyond the service head on new services.
- b) For reconnection of an existing service, the Customer's service conductors shall extend a minimum of 450mm beyond the service head.

#### 12.2.4 Service Entrances Located On Utility Poles:

- a) Service entrances and meters shall not be located on utility poles except for:
  - i) Maypoles (Figures 6 and 7); and
  - ii) Temporary entrances where Utility Approval has been granted; and
  - iii) Overhead services to non-fixed premises, with Utility Approval (see section 12.5 - Non-Fixed Premises).
- b) The above services are only to be located on utility poles which are not supporting primary facilities.
- c) Where a service entrance and meter are installed on a utility pole the service head shall be installed at 150mm below the utility's secondary conductors.

- d) Notwithstanding, unmetered service entrances may be located on approved utility poles including poles supporting primary facilities. As with any entrance location these entrances require prior approval from the Supply Authority. The service head for an unmetered service shall be located 150mm below the secondary conductor.

### **12.3 Underground**

- a) Underground service entrance conductors and conduits are to be owned, installed and maintained by the Customer.
- b) Underground Customer service conductors shall be installed as directed by the utility and in the following manner:
  - i) To a utility pole where a length of service conductor specified by the Supply Authority will be left at the base of the pole for the Supply Authority to secure to the pole and make connections, except in the city of Saint John where rigid PVC conduit and a service head will also be installed to a height as directed by the Utility.
  - ii) To a utility underground secondary enclosure or padmounted transformer with an additional 1.5m of conductor left in enclosures and 2.0m in transformers.
- c) Where an underground service conduit terminates at an outdoor meter enclosure the vertical section of conduit shall be fitted with an expansion joint. Where the expansion joint is comprised of two conduits of different diameter, the outer or larger conduit shall be at the top of the run. Rationale: CE Code rule 12-1118 specifies the requirements for expansion joints for vertical runs of PVC. The above standard assumes that frost conditions in the province are sufficient to cause the 45mm expansion stated in rule 12-1118. Therefore, all such runs shall have an expansion joint.

#### **12.3.1 Service From Padmounted Transformers:**

Where a padmounted transformer is required, the Customer shall contact the utility's engineering department for information regarding transformer pad location and construction standards, trenching and duct installation details, grounding, concrete specifications, cable installation guidelines, etc.

See also section 10.2 - Service Capacity, Three Phase, and section 15.3 Rule 26-242 - Outdoor Transformer Installations.

### **12.4 Temporary Service Entrances**

- a) A temporary service entrance is intended to be used to supply power for construction purposes or to Customers requiring power for duration of less than six months.

- b) Temporary services may be mounted on:
  - i) Construction shacks or trailers equipped with a service mast; or
  - ii) A Customer owned pole or tripod structure (Figure 9) which meets the requirements of CE Code section 76 and is acceptable to the Inspection Authority and the Supply Authority; or
  - iii) On a Utility pole as per section 12.2.4 - Service Entrances Located On Utility Poles.
- c) Utility supplied point of attachment hardware, or an equivalent, shall be installed by the Customer.
- d) The point of attachment shall be located such that the utility supply conductors clearance above finished grade satisfies CE Code rule 6-112, subrule (2).

## 12.5 Non-Fixed Premises

Service for non-fixed premises may be:

- a) Underground service to a Customer's service entrance mounted on a structure to be installed, owned and maintained by the Customer. The structure must meet the requirements of the Inspection Authority and the Supply Authority. A typical structure would consist of two 6" x 6" posts set 1200 mm deep and a plywood back board with dimensions greater than those of the meter base and meet the requirements of 16.3 for meter mounting height; or
- b) Overhead Utility supply conductors to a Customer's service entrance mounted on a utility pole may be considered with Utility Approval (the pole not supporting primary facilities); or
- c) Overhead service to a Customer's service entrance mounted on a Customer owned treated wooden pole, or equivalent, (Figure 8) which meets the following:
  - i) The overall pole length shall be such that the height of the pole after setting allows the utility supply conductors to satisfy the clearance requirements of CE Code rule 6-112, subrule (2); and
  - ii) The pole shall be set to a depth of 10% of the pole length plus 600mm. (Example - a 7.5 metre pole shall have a setting depth of  $750\text{mm} + 600\text{mm} = 1350\text{mm}$ ); and
  - iii) Wooden poles shall have a minimum groundline circumference of 725mm and a minimum top circumference of 475mm; and

- iv) The Customer's entrance shall be mounted such that the service head is located 300mm below the top of the pole; and
- v) A guy and anchor (also Customer owned) is recommended on all installations but shall be installed by a qualified utility contractor where the span exceeds 8m (see note below); and
- vi) The pole installation is acceptable to the Inspection Authority and the Supply Authority.

(Note: CSA C22.3 No. 1 section 3.2.6 - 'Marking Of Guys' states that 'all guys exposed to traffic (including pedestrian traffic, skiers, snowmobiles) shall be equipped with substantial and conspicuous guards'. Utility guy guards meet CSA Standard C83.69. It is recommended that equivalent guards be installed on Customer owned guys.)

## **13. CUSTOMER SERVICE CONDUCTORS**

### **13.1 Conductor Sizes**

The standard copper and aluminum service entrance conductor sizes for overhead and underground services shall meet the requirement of CE Code.

Other conductor sizes and parallel configurations may be acceptable with Utility Approval and approval of the Inspection Authority. See also section 13.2 - Maximum Lengths For Underground Conductors, and section 13.3 - Connectors For Service Entrance Conductors.

### **13.2 Maximum Lengths For Underground Conductors**

Underground service loops must meet the voltage drop requirements of CE Code rule 8-102. Larger conductors may be required where, based on the expected demand current, the calculated voltage drop exceeds the combined limits of rule 8-102, subrule (1), paragraphs (a) and (b).

The service conductors' maximum length also depends on individual feeder and branch circuit voltage drops. Therefore, each installation must be analyzed separately. Analysis is the responsibility of the Customer.

Where the conductor size is increased to overcome voltage drop, the proposed conductor size shall meet the requirements of the Inspection Authority and once approved, the Supply Authority must be notified.

### **13.3 Connectors For Service Entrance Conductors**

The utility will provide and install connectors for the standard service entrance conductor sizes issued by the Inspection Authority to a maximum of 1000 MCM. In the event that non-standard service entrance conductor sizes are used and the utility does not stock a suitable connector, the Customer shall supply the connectors.



## **13.4 Customer's Service Conductor Identification**

### **13.4.1 Phase Conductors:**

Like phases of parallel service entrance conductors shall be so identified.

### **13.4.2 Neutral Conductor:**

As per the CE Code, neutral conductors shall be identified by the color white in a method suitable to the requirements of the Inspection Authority.

## **13.5 TECK90 Cable**

TECK90 cable shall not be used on permanent services. It may be used on temporary services to a padmount transformer or secondary service box.

## **14. CUSTOMER SERVICE EQUIPMENT**

### **14.1 Service Equipment Location**

- a) A Customer's service equipment, including indoor metering equipment, shall be installed as specified in CE Code rule 6-206.
- b) Where meters are located in electrical rooms or premises with normally locked doors, the Customer shall ensure accessibility by way of a key, a keybox, on site personnel, etc.
- c) The Customer shall provide the utility with the same minimum working space and headroom around indoor metering equipment and enclosures as required by CE Code rule 2-308. As stated in the Code, a secure footing shall be provided.
- d) In addition to the above, the utility requires that the following CE Code rules be observed where utility metering equipment or enclosures are located:
  - i) Rule 2-310, subrules (1) to (4) - Entrance To, and Exit From, Working Space
  - ii) Rule 2-314 - Accessibility for Maintenance
  - iii) Table 56 - Minimum Working Space About Electrical Equipment Having Exposed Live Parts
  - iv) Rule 2-326 – Electrical Equipment Near Combustible Gas Meters and Other Devices (meters are considered to be “arc producing electrical equipment” for the purposes of rule 2-326).

## **14.2 Service Disconnect**

- a) As per CE Code rule 6-206, subrule (1), paragraph (c), the main service disconnect shall be located as close as practical to the point where the Customer's service conductors enter the building. In no case shall this distance exceed 5.0 metres as per NB Regulation 84-165.
- b) Conductors meeting the requirements of CE Code rule 6-208 shall be considered to be outside the building.

## **14.3 Fault Current Interrupting Rating**

The utility can provide the fault current levels on the primary distribution system at the service entrance location to allow Customer equipment to be sized to meet the requirements of CE Code rule 14-012, paragraph (a).

## **15. CANADIAN ELECTRICAL CODE RULES REGARDING SERVICE ENTRANCES**

Many utility requirements are covered by C22.1 'The Canadian Electrical Code Part I'.

For reasons such as economics or space for, or on, poles, the Supply Authority sometimes finds it necessary to further limit that which is allowed by the Code. Listed below are various Code rules relating to service entrances and the interests of the Supply Authority.

The local utility shall be consulted when the code requires compliance with the requirements of Supply Authority. Compliance may be enforced by the Inspection Authority at the request of the Supply Authority.

### **15.1 Number Of Supply Services Permitted**

- a) The utility will run only one set of utility supply conductors to any building to avoid electrical hazards for personnel and to permit ease of disconnection during emergency situations.
- b) The CE Code rule 6-102 does not allow two or more supply services of the same voltage and characteristic to any building with exceptions listed in paragraphs (1a), (1b) and (1c). Paragraph (1a), "fire pumps and other emergency systems", is self-explanatory and acceptable to the utility.
- c) Installations allowed by paragraphs (1b) and (1c), covering industrial establishments, complex structures and self-contained occupancies, will have to be assessed individually by the Supply Authority as it is the intent of the utility to run only one set of utility supply conductors to a building. More than one supply service to a building will require Utility Approval.
- d) Where more than one service entrance is approved, rule 6-102 subrules (2) and (3) and rule 6-214 must be observed.

- e) More than one service entrance may be permitted to buildings with completely self-contained occupancies as per Section 11 (SES) - Service To Multiple Occupancy Buildings.

## **15.2 Rule CE Code 14-612 - Transfer Equipment for Standby Power Systems**

- a) Transfer switches for transferring the source of power from the utility system to a standby power system must meet the requirements of CE Code 14-612. The switch shall not allow the two sources to operate in parallel to prevent energizing or backfeeding a de-energized utility distribution line on which crews may be working.
- b) Notwithstanding a), a closed-transition transfer switch may be allowed, with Utility Approval, provided the following conditions are met:
  - i) The transfer controller is set to confirm that the Alternative source's quantities are as follows: Voltage magnitude is within 5% of Utility source; AND Frequency is >59.8Hz; AND Voltage Angle is within 5 degrees of the Utility source.
  - ii) The parallel time shall be <100mS. If the transfer is unsuccessful, and the transfer scheme has determined that the initially closed switch has failed to Open, then the transfer controller shall within 100msec (6 cycles) command the initially open switch to Open. The total Breaker Failure clearing time shall not exceed 500mS.
  - iii) Each switch must have its own operator.
  - iv) A confirmation in writing signed by a professional engineer or professional technician, verifying that the specified transfer switch will be set as per the criteria above.
- c) Other devices such as purpose built meter base accessories that accommodate the connection of standby generators are also acceptable and must have the approval of the Inspection Authority.

## **15.3 Rule CE Code 26-242 - Outdoor Transformer Installations**

The Supply Authority intends to meet the requirements of rule 26-242, subrule (2) regarding the location of liquid filled padmounted distribution transformers near combustible surfaces or materials, windows, doors and ventilation openings. Utility approval is required to allow the transformer location noted in subrules 2(a) and 2(b). Therefore, the Customer must locate the transformer pad to meet the requirements of the applicable subrule.

Subrule 2(a) allows the distances given in subrule (2) to be reduced provided a non-combustible barrier is constructed around the transformer. Construction of the non-combustible barrier is the responsibility of the Customer.

Specifications for a non-combustible barrier are available from the utility, or the Customer may propose an alternative design to the utility's engineering department for Utility Approval.

## **16. METERING**

### **16.1 General Requirements**

- a) All three phase meter installations are three element meters.
- b) There shall be a maximum of one meter per occupancy except by Utility Approval.
- c) If the service consists of a combination of meter installations, then all meters shall be grouped in one location.
- d) CE Code rule 6-408, subrule (2), locating instrument transformers outdoors and the meter indoors, shall not be permitted by the Supply Authority.
- e) Access fittings (LB, LR or LL elbows) are not permitted in conduits used for metering wiring.
- f) All equipment must be approved for the application by a certification organization acceptable to the Inspection Authority.
- g) Rule 2-326 – Electrical Equipment Near Combustible Gas Meters and Other Devices (meters are considered to be “arc producing electrical equipment” for the purposes of rule 2-326).

### **16.2 Location, Access, and Space Requirements**

- a) Before commencing any service entrance installation the Customer shall consult with the Supply Authority to ensure compliance with the requirements of:
  - i) CE Code rule 6-408, subrule (1), paragraphs (a) to (f) regarding location and grouping of, and access to, utility metering equipment; and
  - ii) CE Code rule 6-410 regarding space provisions for utility metering equipment.
- b) A Customer’s service equipment, including indoor metering equipment, shall be installed as specified in CE Code rule 6-206, subrule (1) paragraphs (a) to (c).
- c) The Customer shall provide the utility with the same minimum working space (1m) and headroom (2.2m) around indoor metering equipment and enclosures as required by CE Code rule 2-308, subrules (1) and (5) for working space around electrical equipment.
- d) Floor or grade surfaces around metering equipment shall have a secure footing as per CE Code rule 2-308 - Working Space About Electrical Equipment.

- e) In addition to the above, the utility requires that the following CE Code rules be observed where Utility metering equipment is contained in electrical rooms:
  - i) Rule 2-310, subrules (1) to (4) - Entrance To, and Exit From, Working Space
  - ii) Rule 2-314 - Accessibility for Maintenance
  - iii) Table 56 - Minimum Working Space About Electrical Equipment Having Exposed Live Parts

### **16.3 Meter Mounting Height**

All meters, except those mounted in network meter centers, shall be mounted such that the horizontal centerline of the meter is between 1.5m and 1.7m measured vertically from the finished floor or grade level. If the grade is changed, the Supply Authority may require the meter box to be relocated to address safety hazard. Note: Utility Supply conductors' clearances must be met.

### **16.4 Instrument Transformers And Enclosures**

- a) The electrical contractor is responsible to supply and install all connectors used to make primary connections to the current transformers.
- b) The utility will supply the instrument (current and potential) transformers.
  - i) The Customer shall install the current transformers in a Customer supplied enclosure and make the primary connections. The utility will do the secondary wiring and install the test switch. Current transformers up to and including 1200:5 are bar-type whereas 1500:5 and 3000:5 are window type.
  - ii) All utilities will make the potential transformer connections.
- c) The current transformer enclosure and the meter shall be in the same room. Wiring from the current transformer secondary terminals to the meter shall not exceed 9 metres in length. [Intent: Deviations require analysis of the current transformer secondary circuit to ensure the billing accuracy burden is not exceeded and approval of the utility's metering department.]
- d) Instrument transformer installations shall meet the requirements of CE Code rule 6-404. In addition to the requirements of this rule, instrument transformers shall be mounted in a separate cabinet from the meter with adequate provision for sealing by the Supply Authority.

## **16.5 Metering At Customer Owned Transformers**

Metering shall be installed on the supply side of Customer owned transformers. Where Utility Approval is given to deviate from this requirement, the Customer owned transformer must meet the requirements of CSA C802 (latest revision) - 'Maximum Losses for Distribution, Power, and Dry-Type Transformers'.

## **16.6 Single Phase - 120/240 Volt, Up To 200 Amp, Self-Contained**

This installation uses a 4 jaw meter socket rated for the amperage and voltage of the entrance.

### **Meter Outdoors:**

- a) The meter shall be connected on the supply side of the service box.
- b) For location outdoors (Figure 10) this installation shall not exceed:
  - i) Six meters per supply service; and
  - ii) A total combination of two multiple-meter mounting devices which shall be grouped in one location; and
  - iii) Two service stacks. Note: The service heads shall be located within 300mm of each other for connection to a single set of overhead utility supply conductors; and
  - iv) A combined total rating of 600 amps.

### **Meter Indoors:**

- a) The meter shall be connected on the load side of the service box.
- b) This meter installation shall be indoors where the number of meters exceeds six.

## **16.7 Single Phase - 120/240 Volt, 201 To 600 Amp, Current Transformer Connected**

This installation uses;

- a) a 5 jaw meter socket rated for 20 amps, a test switch and a 500mm x 500mm x 250mm current transformer cabinet; or
- b) an approved pre-wired meter socket which includes the test switch and current transformer. (Note: check with the utility regarding programs for reimbursement of the cost of the test switch and current transformer when pre-wired boxes are installed.)

**Meter Outdoors:**

- a) Location
  - i) On residential or commercial buildings, the meter, test switch and current transformer may be located outdoors, on the supply side of the service box, when installed in a pre-wired enclosure (meter, test switch and CT's all in same enclosure) approved by the Supply Authority (Figure 3); or
  - ii) On residential buildings, and for 600 amps only, the meter and test switch may be located outdoors and the current transformers located indoors, on the load side of the service box.

**Meter Indoors:**

- a) Location
  - i) On commercial buildings the meter and current transformers shall be located indoors, on the load side of the service box (Figure 4), except as provided for by Meter Outdoors a), i) above.
  - ii) The current transformer enclosure and the meter shall be in the same room. Wiring from the current transformer secondary terminals to the meter shall not exceed 9 metres in length.

**16.8 Network - 120/208 Volt, Up To 200 Amp, Self-Contained**

- a) This installation uses a 5 jaw meter socket rated for the amperage and voltage of the entrance.
- b) Each network meter shall be connected on the supply side of the service box for the occupancy associated with the meter.
- c) Meters for this installation shall only be located indoors.
- d) Each meter and corresponding subswitch shall be clearly and permanently identified to indicate which occupancy it serves.
- e) The neutral conductor shall run through the socket and be connected to the neutral lug.

### **16.9 Three Phase - 120/208 Volt, Up To 200 Amp, Self-Contained**

This installation uses a 7 jaw meter socket rated for the amperage and voltage of the entrance.

The neutral conductor shall run through the socket and be connected to the neutral lug.

#### **Meter Outdoors:**

- a) The meter shall be connected on the supply side of the service box.
- b) For location outdoors this meter installation shall not exceed:
  - i) Six meters per supply service; and
  - ii) A combined total rating of 600 amps; and
  - iii) A total combination of two multiple-meter mounting devices which shall be grouped in one location; and
  - iv) Two service stacks. Note: The service head shall be located within 300mm of each other for connection to a single set of utility supply conductors.

#### **Meter Indoors:**

- a) This meter installation shall be indoors where the number of meters exceeds six.
- b) The meter shall be connected on the load side of the service box.

### **16.10 Three Phase - 120/208 Volt, 201 To 2000 Amp, Current Transformer Connected**

This installation uses a 13 jaw meter socket rated for 20 amps, a test switch and a 760mm x 760mm x 250mm current transformer cabinet.

#### **Meter Outdoors:**

- a) On residential or commercial buildings, the meter, test switch and current transformers may be located outdoors when installed in an enclosure approved by the Supply Authority.
- b) The meter shall be connected on the supply side of the service box.

#### **Meter Indoors (Figure 5):**

- a) The current transformer enclosure and the meter shall be in the same room. Wiring from the current transformer secondary terminals to the meter shall not exceed 9 metres in length.
- b) The meter shall be connected on the load side of the service box.



### **16.11 Three Phase - 347/600 Volt, Up To 200 Amp, Self-Contained**

- a) This installation uses a 7 jaw meter socket rated for the amperage and voltage of the entrance.
- b) Meters for this installation shall only be located indoors.
- c) The meter shall be connected on the load side of the service box.
- d) The neutral conductor shall run through the socket and be connected to the neutral lug.

### **16.12 Three Phase - 347/600 Volt, 201 To 2000 Amp, Potential And Current Transformer Connected**

Refer to Figure 5.

- a) This installation uses a 13 jaw meter socket rated for 20 amps, a test switch and a 915mm x 915mm x 250mm transformer cabinet.
- b) Meters for this installation shall only be located indoors.
- c) The meter shall be connected on the load side of the service box.
- d) The instrument transformer enclosure and the meter shall be in the same room. Wiring from the current transformer secondary terminals to the meter shall not exceed 9 metres in length.

## **17. METERING SPECIFICATION FOR CUSTOMER OWNED SWITCHGEAR**

### **17.1 Scope**

This specification applies to revenue metering equipment in Customer owned metal clad or metal-enclosed switchgear of three phase four wire grounded wye circuits at 120/208, 347/600, 2400/4160 or 7200/12,470 volts. Service at 14,400/24,940 volts may also be available with utility approval.

### **17.2 Inspection or Qualification**

Generally, any inspection, qualification or acceptance tests applying to the switchgear unit as a whole must include the metering equipment.

### **17.3 Reference**

The metering equipment must be installed and connected in accordance with, and observance of, the Canadian Electrical Code and the Utility Service Entrance Standard.

Revenue metering equipment is for utility use only. The connection of Customer owned load control equipment to utility equipment may be permitted with utility approval.

## 17.4 Detailed Requirements

### A. Current Transformers:

#### i) Current Transformers Supplied By The Supply Authority

The Supply Authority will provide the required current transformers (3 - one per phase) to the switchgear manufacturer for mounting on the main incomer, on the load side of the main breaker.

#### ii) Current Transformers Supplied by The Customer

This option must be approved by the supply authority;

- a) The current transformers must be approved for revenue metering in Canada. The Measurement Canada approval number must be supplied to the Supply Authority. Current transformer accuracy class must be 0.3 B 0.9 minimum.
- b) Current transformers shall be rated for the voltage and maximum capacity of the entrance.
- c) The current transformer ratio and type will be specified by the Supply Authority at the time of purchase. Dual ratio current transformers may be required.
- d) Current transformers having NEMA standard dimensions must be used wherever possible.

#### iii) Connections

- a) Primary connections must be made such that the current transformers H1 polarity marks are toward the source side of the circuit.
- b) Secondary connections must be brought out to a suitable and accessible stud type terminal block where ratio changes or tests can readily be performed.

#### iv) Mounting

- a) Current transformers shall be mounted so as to be readily accessible for replacement or inspection, and with their name-plates readable when energized.
- b) Window-type current transformers shall be staggered so that the center transformer is lower than the two outside transformers. This is to minimize flux linkage between transformers.

## B. Potential Transformers

- i) The Supply Authority will provide and install the potential transformers. The three potential transformers must be connected phase-to-neutral on four wire wye circuits.
- ii) Where the potential transformers are supplied by the Customer, the transformers must be approved for revenue metering in Canada. The Measurement Canada approval number must be supplied to the Supply Authority. Potential transformer accuracy must be 0.3W 0.6X minimum.
- iii) Potential transformers shall be rated as follows:
  - a) 360/120 for 347/600 volt wye circuits
  - b) 7200/120 for 12,470/7200 volt wye circuits
  - c) 14,400/120 for 24,940/14,400 volt wye circuits
  - d) 2400/120 for 4160/2400 volt circuits
- iv) The switchgear manufacturer will ensure provisions for the utility to seal or lock the potential transformer compartment.
- v) Potential transformers having NEMA standard dimensions must be used wherever possible.
- vi) Mounting
  - a) 2400/120, 7200/120 and 14,400/120 volt potential transformers shall be mounted in an approved type tip-out or draw-out drawer having positive make spring type contacts on both the primary and secondary sides. High voltage fuses must be mounted on the transformer in such a way that they may be readily removed when the drawer is in the open position. An automatic high voltage grounding device is to be provided for each potential transformer. The grounding device will engage when the drawer is in the open position.
  - b) Mounting space for 360/120 volt potential transformers shall be a minimum of 200mm x 200mm x 200mm for each transformer.
- vii) Connections

Potential transformer primary connections may be made to any point on the switchgear's main bus on the source side of the current transformer.

viii) Fuses

Primary fuses are to be provided on each 7200/120 volt, 14,400/120 volt, and 2400/120 volt potential transformer, one fuse in each line from the main bus. A fuse may not be used in the common return lead to the grounded neutral.

Secondary fusing shall be of the cartridge type and mounted at the rear of the panel between the terminal block and the test switch.

Three spare primary and three spare secondary fuses shall be supplied with the switchgear.

C. Secondary Wire

- i) Panel wiring shall be not less than #12 AWG solid wire of a type approved for switchgear use.
- ii) All wires shall be identified by colored insulation or a marking or tagging system.
- iii) Wires passing through steel panels shall be protected by a rubber grommet.
- iv) All terminal blocks are to be the stud type.
- v) Separate terminal blocks are to be provided for current transformer and potential transformer secondary terminations. All terminal block connections shall be identified and made in sequence. All terminal blocks must be of the stud type and be sealable or located in a compartment that is sealable by the Supply Authority.

D. Grounding

The current transformer secondary circuit shall be grounded at one point at the test switch. No other current transformer secondary ground is permitted.

The potential transformer secondary neutral shall be grounded at the test switch.

E. Location of Meters and Test Switch

- i) Where it is possible to locate the meter socket and test switch in a compartment within the switchgear, the minimum dimensions shall be 500mm wide by 600mm high by 250mm deep.

The meter and instrument transformers must be separate compartments or separated by a steel panel on which the meter and test switch may be mounted. The steel panel must be hinged or removable if it provides the only access to any instrument transformers located behind it. The access door to the compartment must have adequate means for locking or sealing.

A bushed hole, at least 37mm in diameter, shall be provided between the instrument transformer and meter compartments for the passage of secondary wires.

- ii) The meter and test switch may both be in a separate metal meter cabinet.

When the meter socket is remotely located, rigid conduit sized not less than 37mm for a 4 wire circuit must be installed between the meter socket and the instrument transformer compartment. The current transformer secondary conductors must not exceed 9 metres.

- iii) It is permissible to locate the meter and test switch within the same compartment as the instrument transformers if a safety barrier provides isolation between the transformers and the meter and test switch. The safety barrier's insulation rating must be equal to or exceed the voltage rating of the switchgear.
- iv) The words "METER INSIDE - CAUTION" are to be labeled in red or yellow on the outside of any door leading in to a meter enclosure. Current and potential transformer enclosures shall be labeled "CT's INSIDE" and "PT's INSIDE", respectively.

## **17.5 Submission of Drawings**

Prior to fabrication, the manufacturer is required to provide drawings to the utility engineer for approval. The drawings shall show the metering panel layout and wiring schematic.

## **17.6 Costs**

Except for the instrument transformers, test switches and associated wiring, all mounting facilities required for revenue metering outlined herein are to form part of the basic switchgear as required and is to be paid for by the Customer.



Énergie NB Power

# UTILITY SERVICE ENTRANCE STANDARD

REVISION:

01

SUBJECT:

SERVICE MAST EXTENDING THROUGH ROOF

E.D.:

FIG.1

EFF. DATE:

JAN 1999

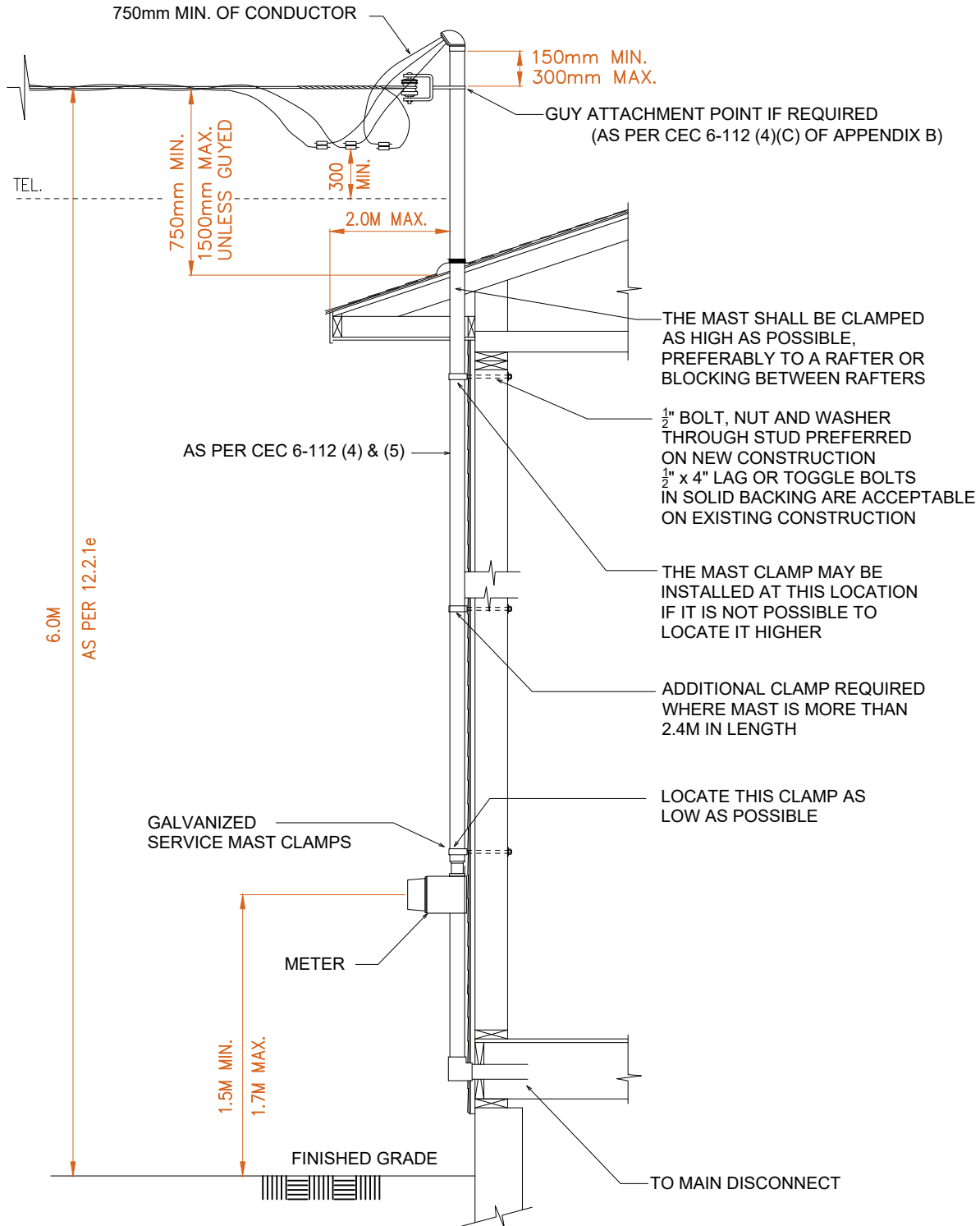



# UTILITY SERVICE ENTRANCE STANDARD

REVISION:

01

SUBJECT:

SERVICE POINT OF ATTACHMENT ON WALL

E.D.:

FIG.2

EFF. DATE:

JAN 1999

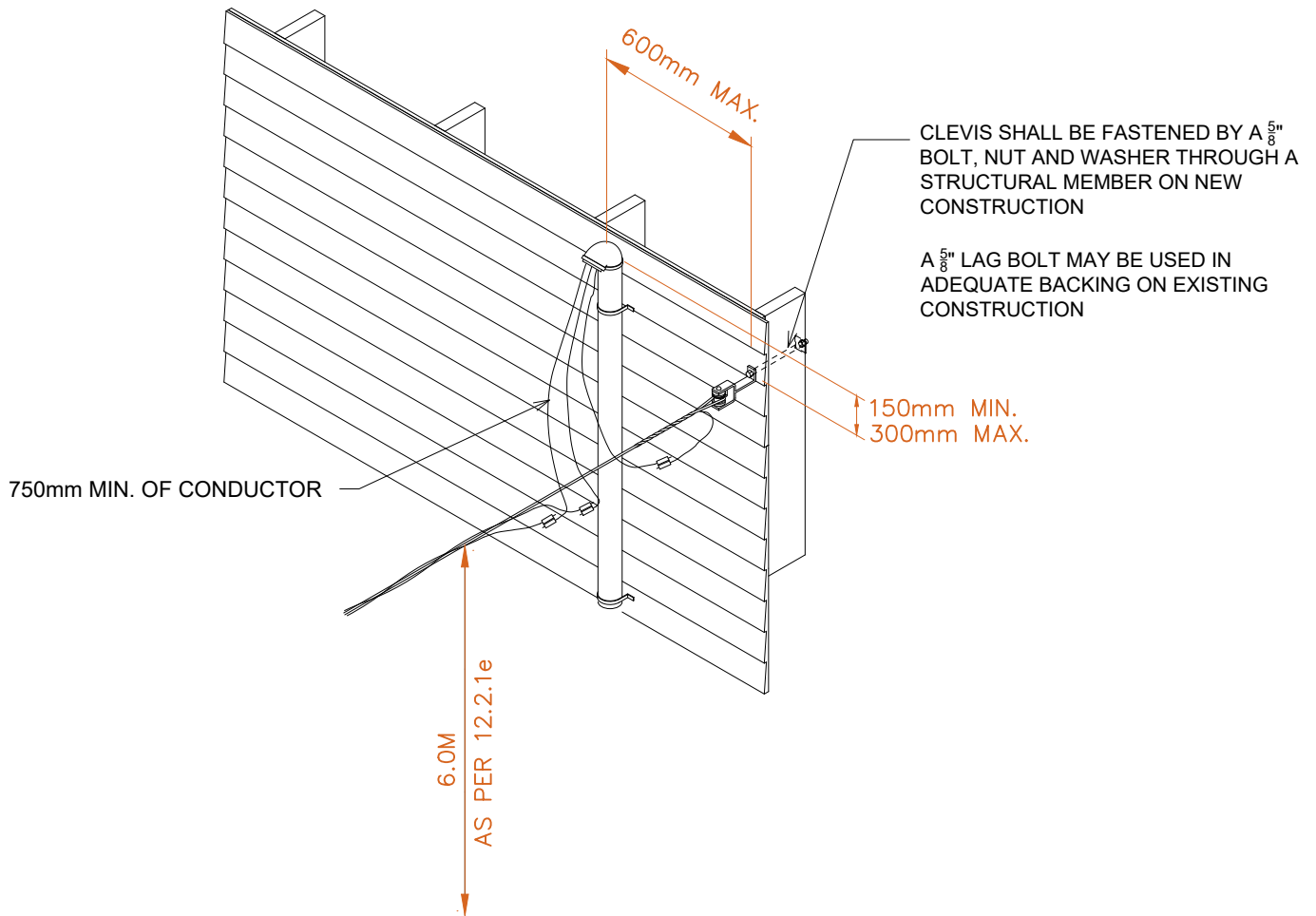



Énergie NB Power

# UTILITY SERVICE ENTRANCE STANDARD

REVISION:

01

SUBJECT:

**PRE-WIRED SINGLE PHASE  
120/240 VOLT, 201 TO 600 AMP  
CURRENT TRANSFORMER CONNECTED ENCLOSURE**

E.D.:

**FIG.3**

EFF. DATE:

JAN 1999

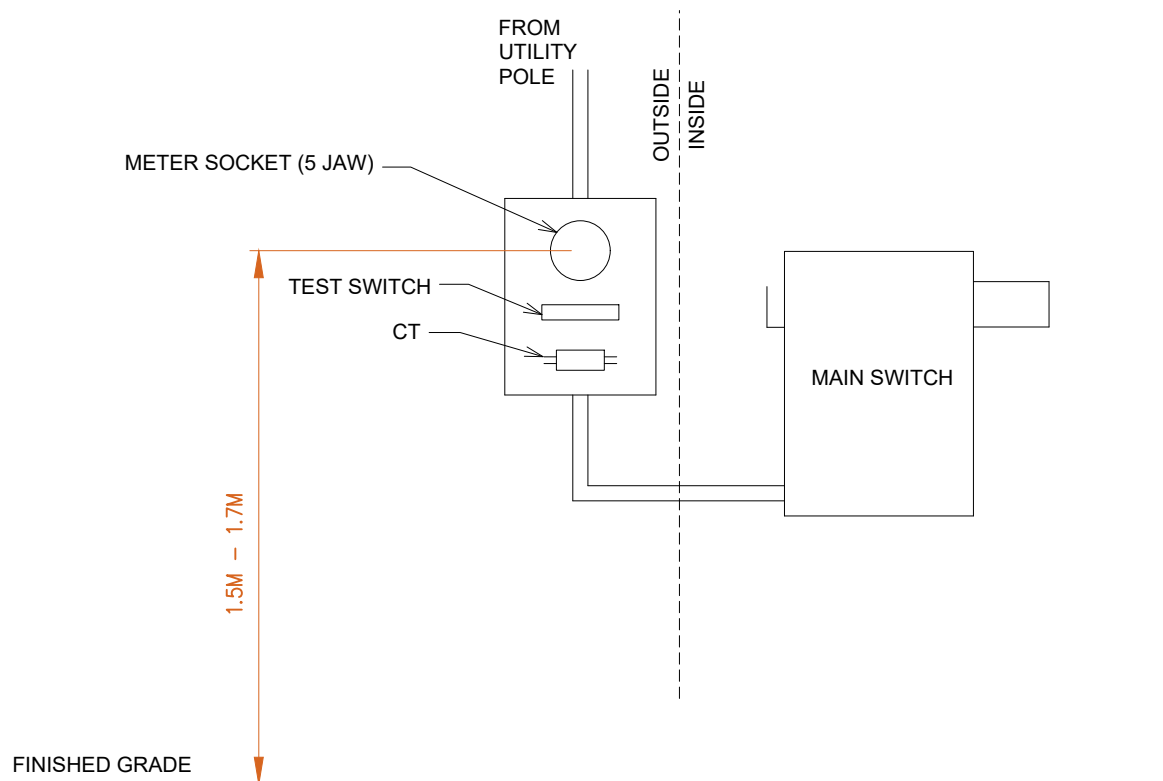

METER BOX IS PURCHASED COMPLETE WITH METER SOCKET (5 JAW) TEST SWITCH AND CURRENT TRANSFORMER PREWIRED. THE UTILITY WILL REIMBURSE THE UTILITY'S COST FOR THE TEST SWITCH AND CURRENT TRANSFORMER. CONSULT THE LOCAL SUPPLY AUTHORITY FOR REIMBURSEMENT PROCEDURES.





Énergie NB Power

# UTILITY SERVICE ENTRANCE STANDARD

REVISION:

01

SUBJECT:

**SINGLE PHASE  
120/240 VOLT, 201 TO 600 AMP  
CURRENT TRANSFORMER CONNECTED**

E.D.:

## FIG.4

EFF. DATE:

JAN 1999

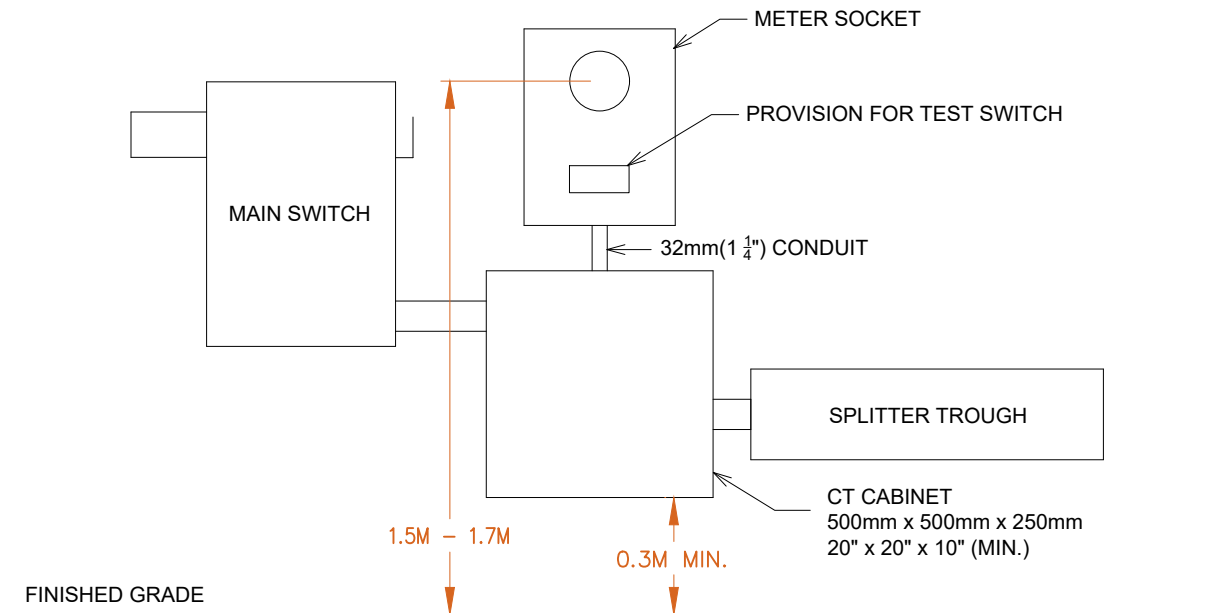

THE INSTALLATION SHOWN INCLUDES A METER SOCKET (5 JAW) WITH PROVISION FOR TEST SWITCH. IN LOCATIONS WHERE METER DAMAGE IS A DISTINCT POSSIBILITY, THE UTILITY MAY REQUIRE THE CONTRACTOR TO INSTALL A 20" x 30" METER CABINET INSTEAD OF THE METER SOCKET SHOWN.



# UTILITY SERVICE ENTRANCE STANDARD

REVISION:

01

SUBJECT:

**THREE PHASE  
120/208 OR 347/600 VOLT  
201 to 2000 AMP**

E.D.:

## FIG.5

EFF. DATE:

JAN 1999

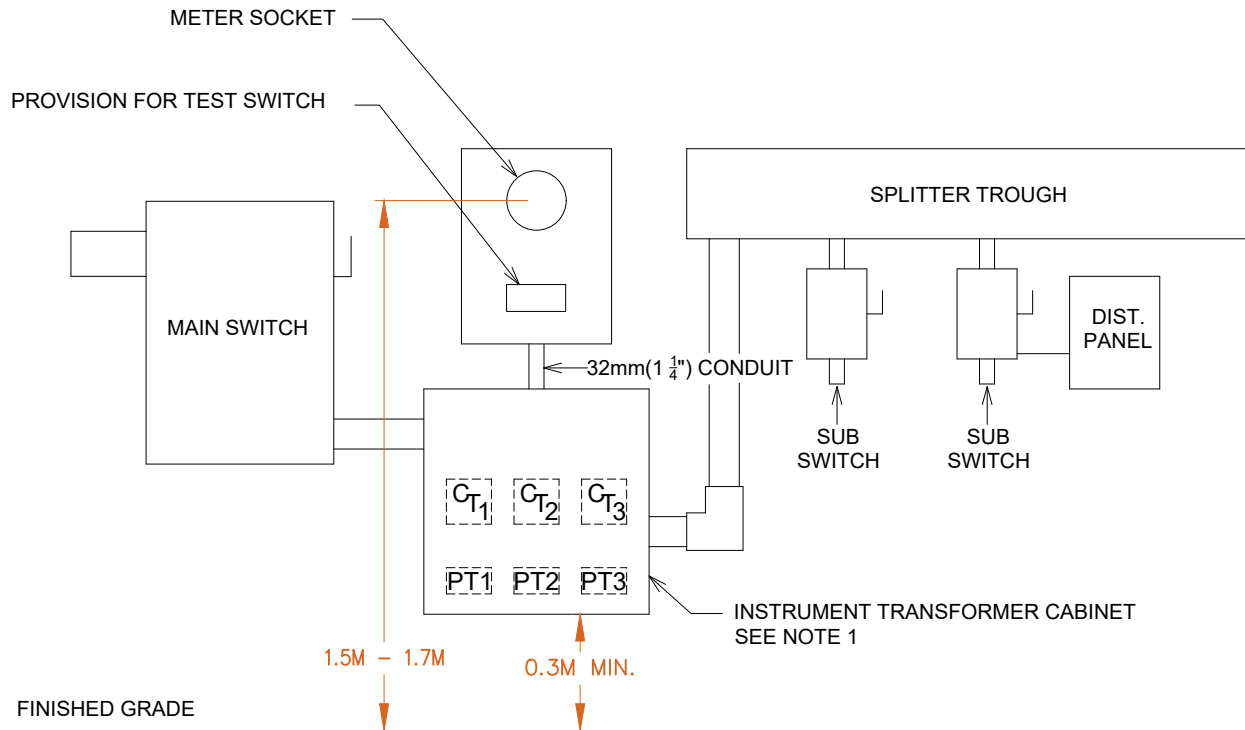

THE STANDARD INSTALLATION SHOWN INCLUDES A METER SOCKET (13 JAW) WITH PROVISION FOR TEST SWITCH. IN LOCATIONS WHERE METER DAMAGE IS A DISTINCT POSSIBILITY, THE UTILITY MAY REQUIRE THE CONTRACTOR TO INSTALL A 20" x 30" METER CABINET INSTEAD OF THE METER SOCKET SHOWN.

### NOTES

1. THE INSTRUMENT TRANSFORMER CABINET MUST BE:
  - 760mm x 760mm x 250mm (30"x30"x10") AT 120/208 VOLT
  - 915mm x 915mm x 250mm (36"x36"x10") AT 347/600 VOLT



Énergie NB Power

# UTILITY SERVICE ENTRANCE STANDARD

REVISION:

01

SUBJECT:

CURRENT TRANSFORMER CONNECTED MAYPOLE  
120/240 VOLT 400 AMP

E.D.:

FIG.6

EFF. DATE:

JAN 1999

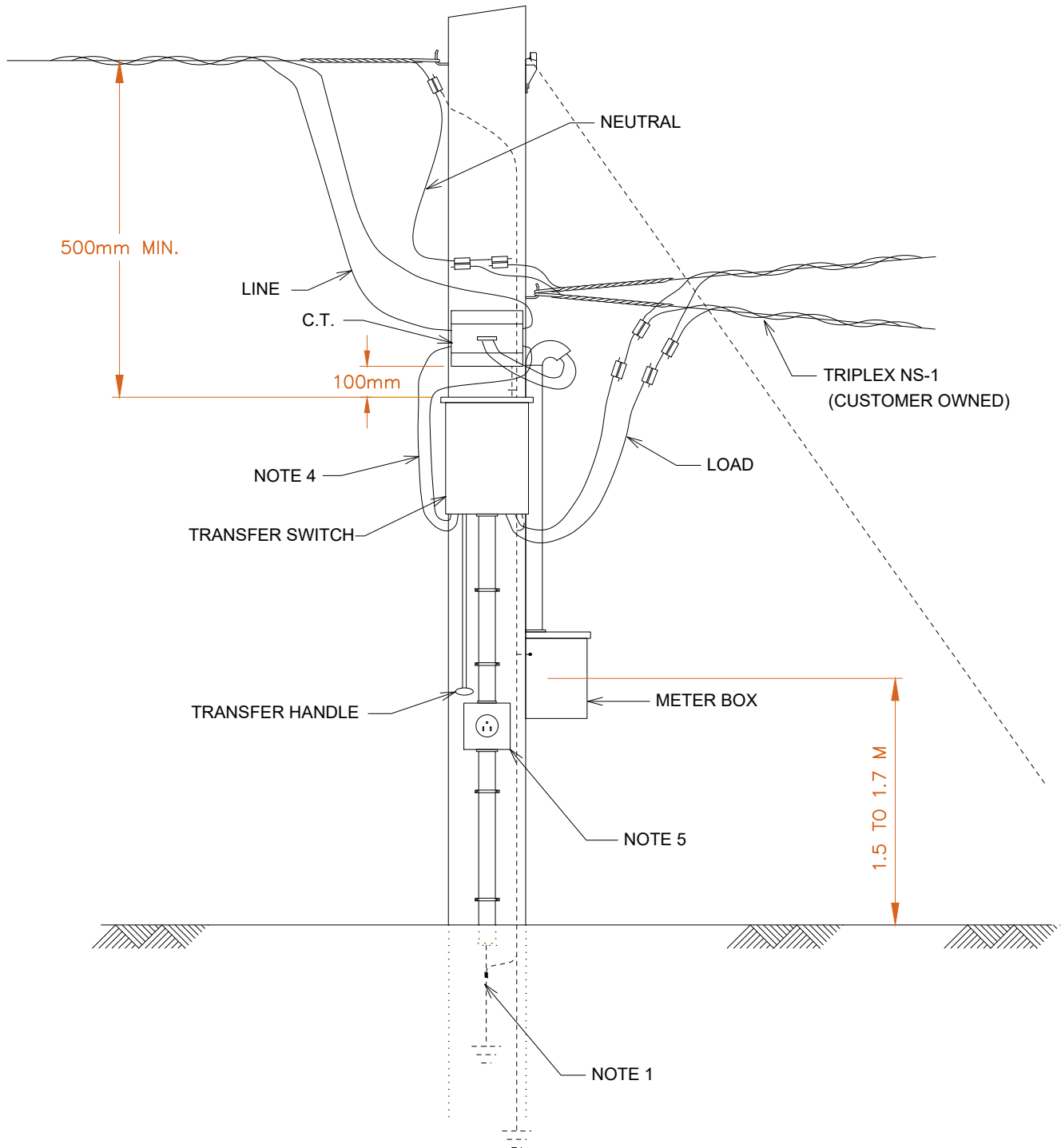

REVISION:	01	SUBJECT: <b>CURRENT TRANSFORMER CONNECTED MAYPOLE 120/240 VOLT 400 AMP</b>	E.D.:
EFF. DATE:	JAN 1999		<b>FIG.6</b>

**NOTES:**

1. INTERCONNECT BUTT GROUND AND GROUND ELECTRODE WITH #6 COPPER.
2. THE CURRENT TRANSFORMER WILL BE SUPPLIED BY THE UTILITY EXCEPT WHERE IT IS PART OF THE TRANSFER SWITCH AND HAS THE METERING ACCURACY SPECIFIED BY MEASUREMENT CANADA.
3. CUSTOMER OWNED CONDUCTORS, SERVICE LOOPS, GROUNDING CONDUCTORS, CONDUITS, ETC. SHALL BE SIZED IN ACCORDANCE WITH THE REQUIREMENTS OF NB DEPARTMENT OF PUBLIC SAFETY - TIS AND THE CANADIAN ELECTRICAL CODE.
4. THE CUSTOMER INSTALLS THE SERVICE EQUIPMENT ON THE POLE AND LEAVES SUFFICIENT CONDUCTOR AT THE TRANSFER SWITCH FOR THE UTILITY TO MAKE CONNECTIONS TO THE CURRENT TRANSFORMER AND UTILITY SUPPLY CONDUCTORS.
5. MALE RECEPTACLE FOR EMERGENCY POWER SUPPLY CABLE.
6. THE LINE CONDUCTORS SHALL BE BLACK; THE LOAD CONDUCTORS SHALL BE RED OR OTHERWISE IDENTIFIED BY PERMANENT MARKINGS AT ALL VISIBLE LOCATIONS.



Énergie NB Power

# UTILITY SERVICE ENTRANCE STANDARD

REVISION:

01

SUBJECT:

SELF-CONTAINED MAYPOLE  
120/240 VOLT 200 AMP

E.D.:

FIG.7

EFF. DATE:

JAN 1999

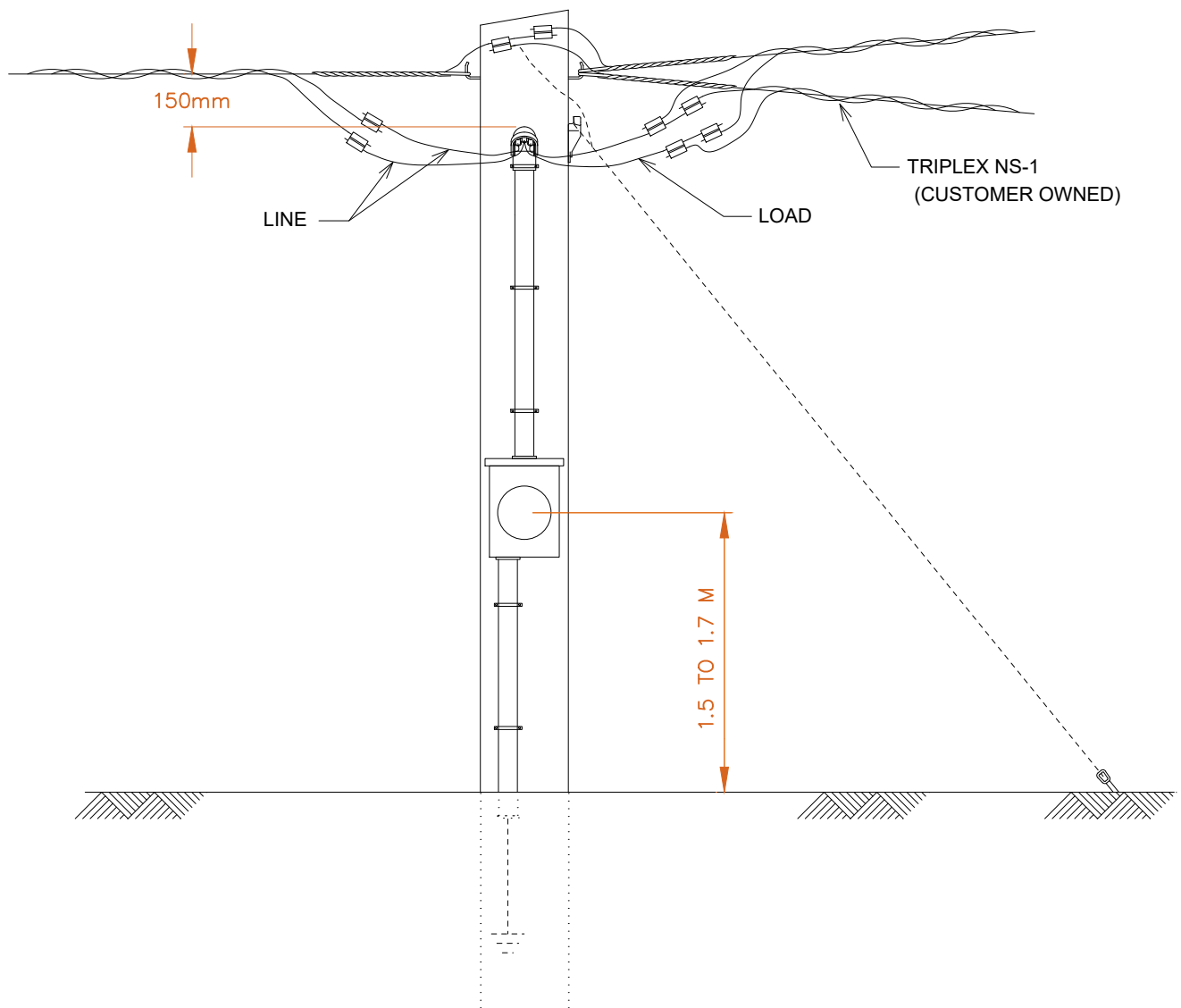

REVISION:	01	SUBJECT:	E.D.:
EFF. DATE:	JAN 1999	SELF-CONTAINED MAYPOLE 120/240 VOLT 200 AMP	FIG.7

**NOTES:**

1. THE CUSTOMER SERVICE CONDUCTORS SHALL EXTEND A LEAST 750mm BEYOND THE SERVICE HEAD.
2. THE LINE CONDUCTORS SHALL BE BLACK; THE LOAD CONDUCTORS SHALL BE RED OR OTHERWISE IDENTIFIED BY PERMANENT MARKINGS AT ALL VISIBLE LOCATIONS.
3. CUSTOMER OWNED CONDUCTORS, SERVICE LOOPS, GROUNDING CONDUCTORS, CONDUITS, ETC. SHALL BE SIZED IN ACCORDANCE WITH THE REQUIREMENTS OF NB DEPARTMENT OF PUBLIC SAFETY - TIS AND THE CANADIAN ELECTRICAL CODE.
4. THE CUSTOMER INSTALLS THE SERVICE EQUIPMENT ON THE POLE AND THE UTILITY MAKES CONNECTIONS TO THE SECONDARY AND SERVICE LOOPS.
5. INTERCONNECT BUTT GROUND AND GROUND ELECTRODE WITH #6 COPPER.
6. PARALLEL MASTS ARE ACCEPTABLE.



Énergie NB Power

# UTILITY SERVICE ENTRANCE STANDARD

REVISION:

01

SUBJECT:

CUSTOMER OWNED POLE  
FOR NON FIXED PREMISE

E.D.:

FIG.8

EFF. DATE:

JAN 1999

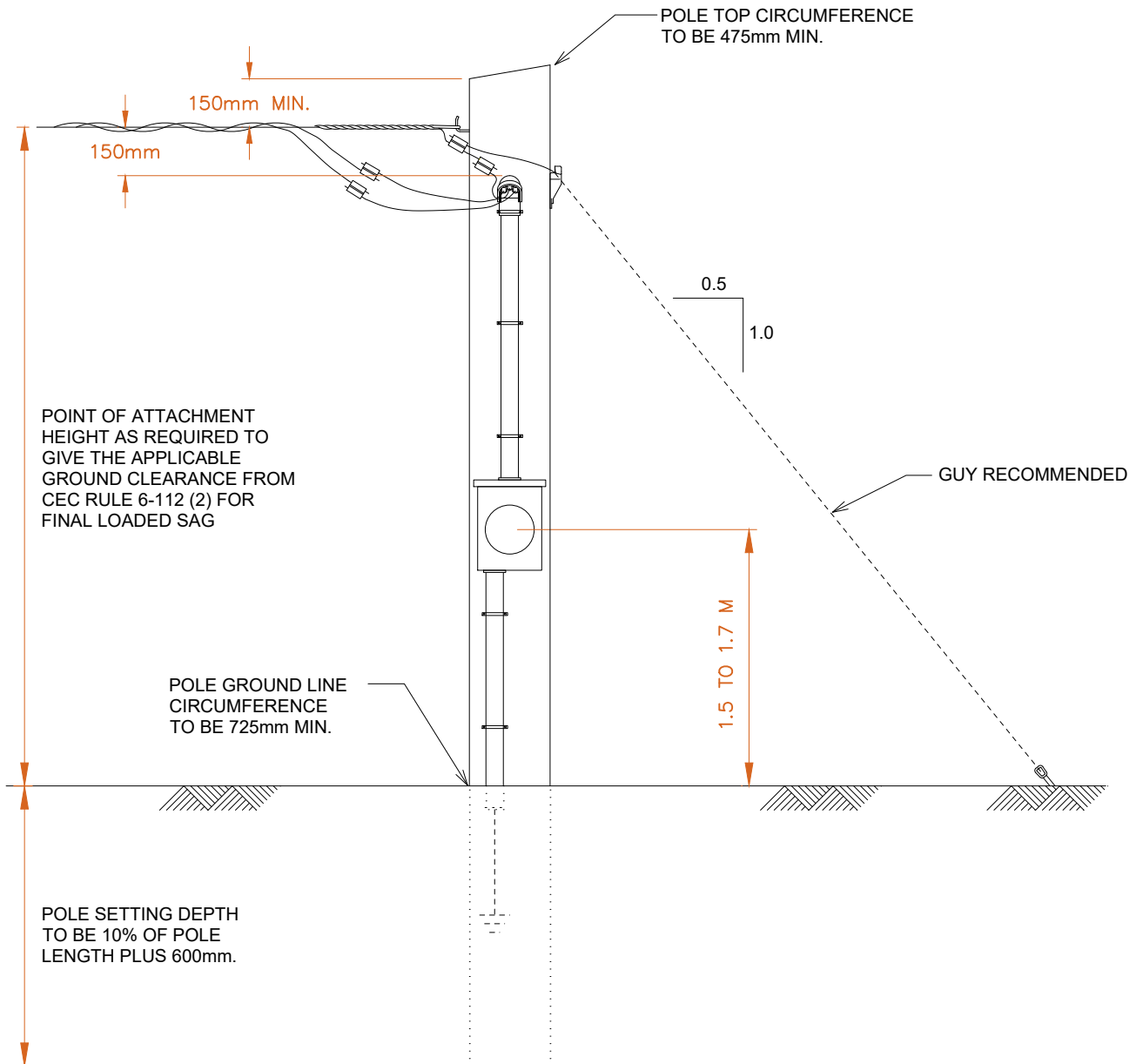

# UTILITY SERVICE ENTRANCE STANDARD

REVISION: 01

SUBJECT: TEMPORARY SERVICE ENTRANCE  
TRIPOD MOUNTED

E.D.: FIG.9

EFF. DATE: JAN 1999

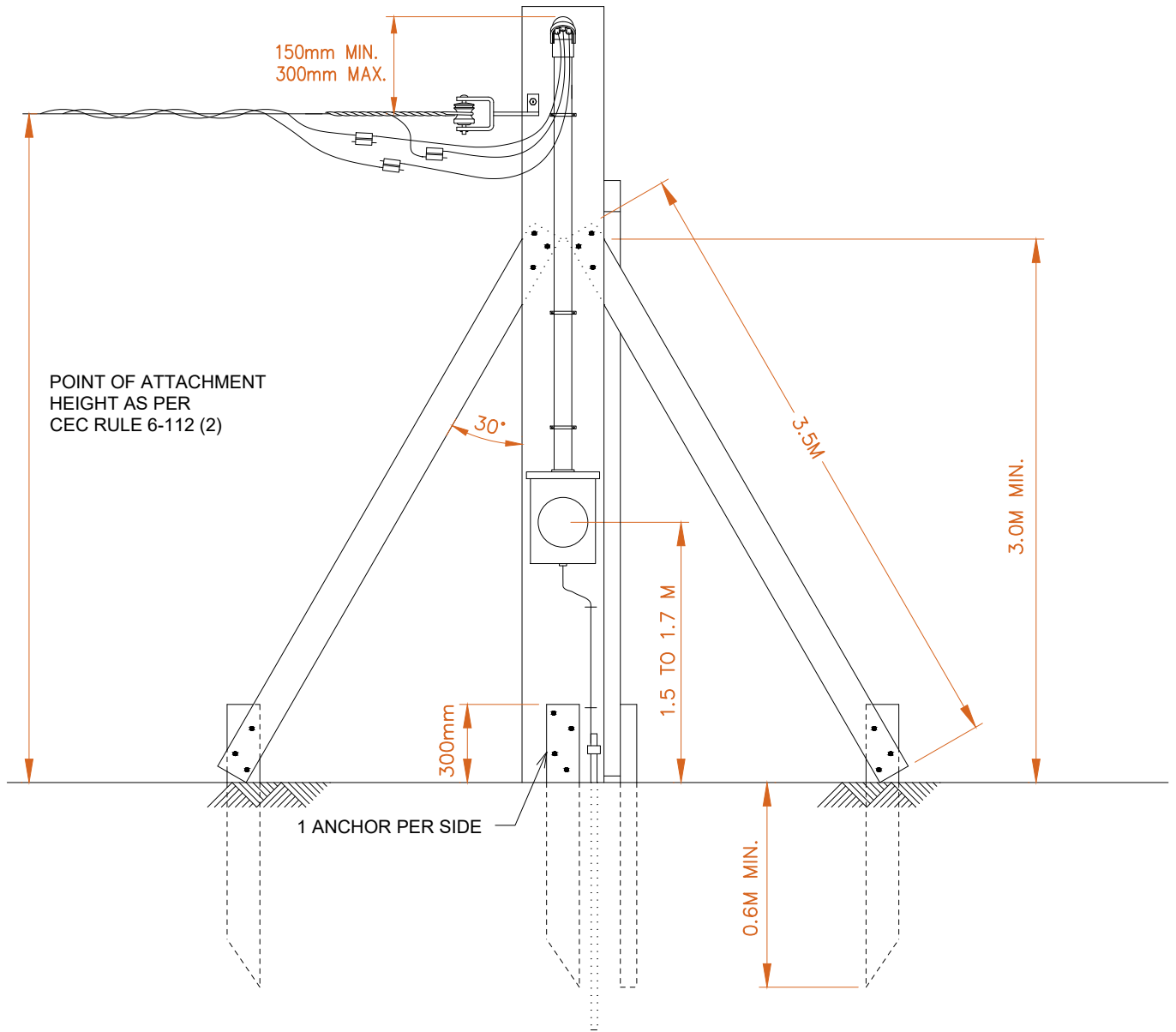



REVISION:	01	SUBJECT: <b>TEMPORARY SERVICE ENTRANCE TRIPOD MOUNTED</b>	E.D.:
EFF. DATE:	JAN 1999		<b>FIG.9</b>

**NOTES:**

1. THE MAIN SUPPORT SHALL CONSIST OF TWO 50mm X 150mm PLANKS NAILED TOGETHER.
2. THERE SHALL BE A MINIMUM OF THREE 50mm X 100mm SUPPORT BRACES. BRACES SHALL BE BOLTED TO THE MAIN SUPPORT AND THE BRACE ANCHORS USING TWO -  $\frac{3}{8}$ " BOLTS OR THREE - COMMON NAILS .
3. ONE BRACE SHALL BE IN LINE WITH THE SERVICE LOOP.
4. BRACE ANCHORS SHALL BE AT LEAST 50mm X 100mm.
5. WHERE A 3M GROUND ROD IS USED AS A GROUND ELECTRODE, IT SHALL BE DRIVEN BELOW GRADE OR KEPT CLOSE TO THE MAIN SUPPORT OR A BRACE ANCHOR TO ELIMINATE ANY TRIPPING HAZARD. GROUND PLATES ARE ALSO ACCEPTABLE AS PER CE CODE RULE 10-702(4).
6. THE TRIPOD SHOULD BE LOCATED AS CLOSE AS POSSIBLE TO THE UTILITY SERVICE POLE AND WITHIN 27M.
7. THE MAIN SUPPORT OR BRACES SHALL NOT CONTAIN SPLICES.
8. THE MAST AND SERVICE HEAD SHALL NOT EXTEND BEYOND THE CENTER SUPPORT.
9. WHERE A TEMPORARY IS SUPPLIED BY UNDERGROUND SERVICE CONDUCTORS, THE UTILITY SUPPLY CONDUCTORS MUST BE MECHANICALLY PROTECTED AS PER THE REQUIREMENTS OF THE CE CODE AND THE INSPECTION AUTHORITY.
10. RECEPTACLE CSA CONFIG. 5-15R OR 20R PROTECTED BY GFCI, CLASS A.
11. REFER TO TIS BULLETIN 76-1-1.



Énergie NB Power

# UTILITY SERVICE ENTRANCE STANDARD

REVISION: 01

SUBJECT:

E.D.:

## FIG.10

OUTDOOR METERING

EFF. DATE: JAN 1999

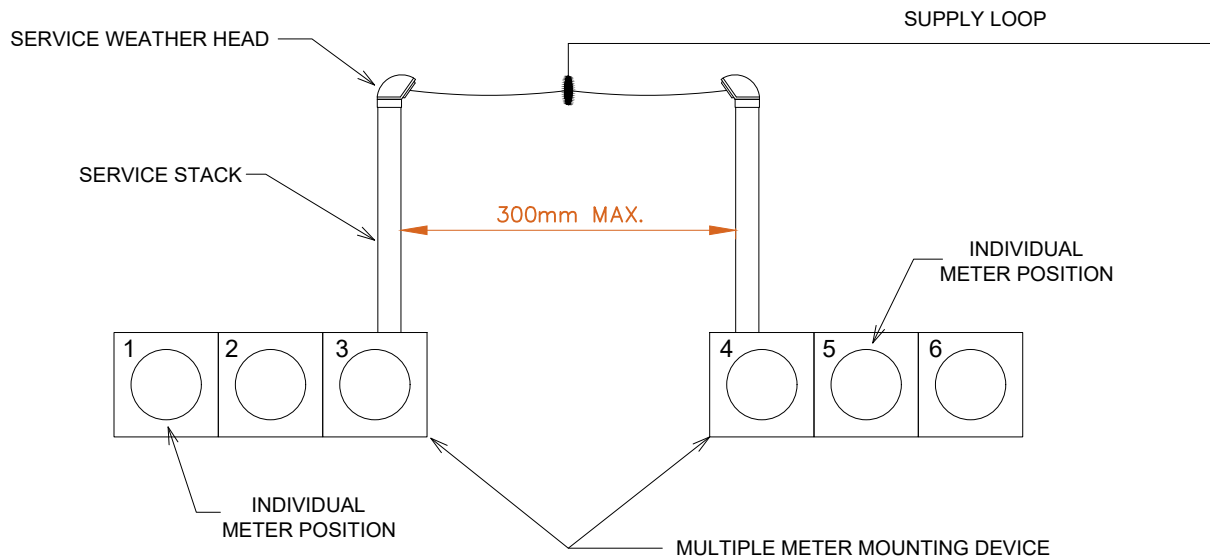



## UTILITY SERVICE ENTRANCE STANDARD

REVISION:

01

SUBJECT:

UTILITY METERING EQUIPMENT - SUMMARY

E.D.:

# FIG.11

EFF. DATE: JAN 1999

No.	Service Entrance Description	Electrician / Contractor Must Supply		Typical Installations
		Meter Socket	Current Transformer Cabinet	
1	120/240 Volts single phase up to 200 Amps	4 jaw socket rated for service entrance Amps & Voltage	None	Residential Commercial
2a	120/240 Volts single phase 201 to 600 Amps	5 jaw socket rated 20 Amps with provision for test switch	500mm x 500mm (min.)	Residential
				Commercial
<b>OR</b>				
2b	120/240 Volts single phase 201 to 600 Amps	Pre-wired meter Socket / CT / Test Switch	None	Residential Commercial
3	120/208 Volts two phase up to 200 Amps (Network)	5 jaw socket rated for service entrance Amps & Voltage	None	Apartments
4	120/208 or 347/600 Volts three phase up to 200 Amps	7 jaw socket rated for service entrance Amps & Voltage	None	Commercial Industrial
5	120/208 or 347/600 Volts three phase 201 to 1200 Amps	13 jaw socket rated 20 Amps with provision for test switch	760mm x 760mm (120/208V) or 915mm x 915mm (347/600V)	Commercial Industrial

REVISION: 01

SUBJECT:

E.D.:

## FIG.12

EFF. DATE: JAN 1999

CURRENT TRANSFORMERS

### SINGLE PHASE 120/240V (201-600 AMPS)

3 WIRE BAR CT

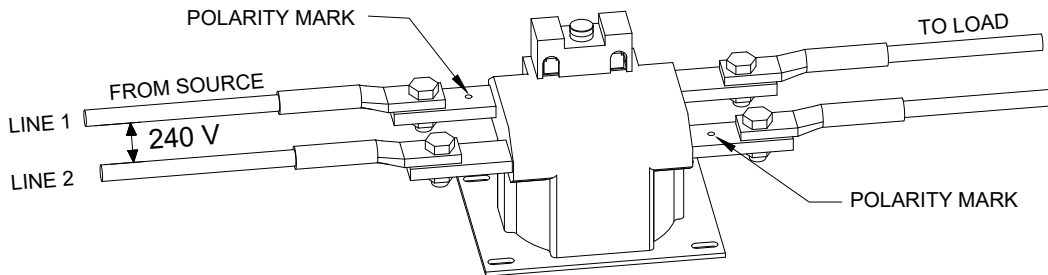

### THREE PHASE SERVICES (201-1200 AMPS)

2 WIRE BAR CT

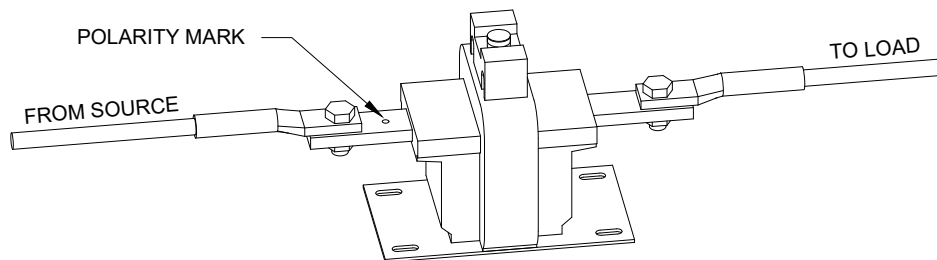

(ONE PER PHASE)

### THREE PHASE SERVICES (1201-3000 AMPS)

2 WIRE WINDOW CT

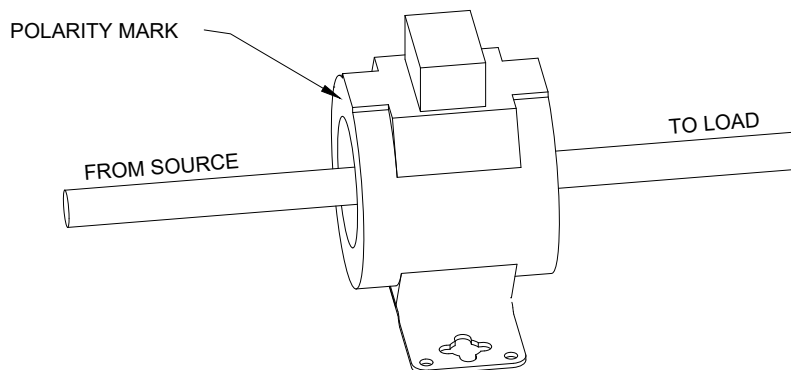

(ONE PER PHASE)



Énergie NB Power

# UTILITY SERVICE ENTRANCE STANDARD

REVISION:

01

SUBJECT:

MUNICIPAL FESTIVE LIGHTING SUPPLIED  
DIRECTLY FROM NB POWER DISTRIBUTION SYSTEM

E.D.:

FIG.13

EFF. DATE:

JAN 1999

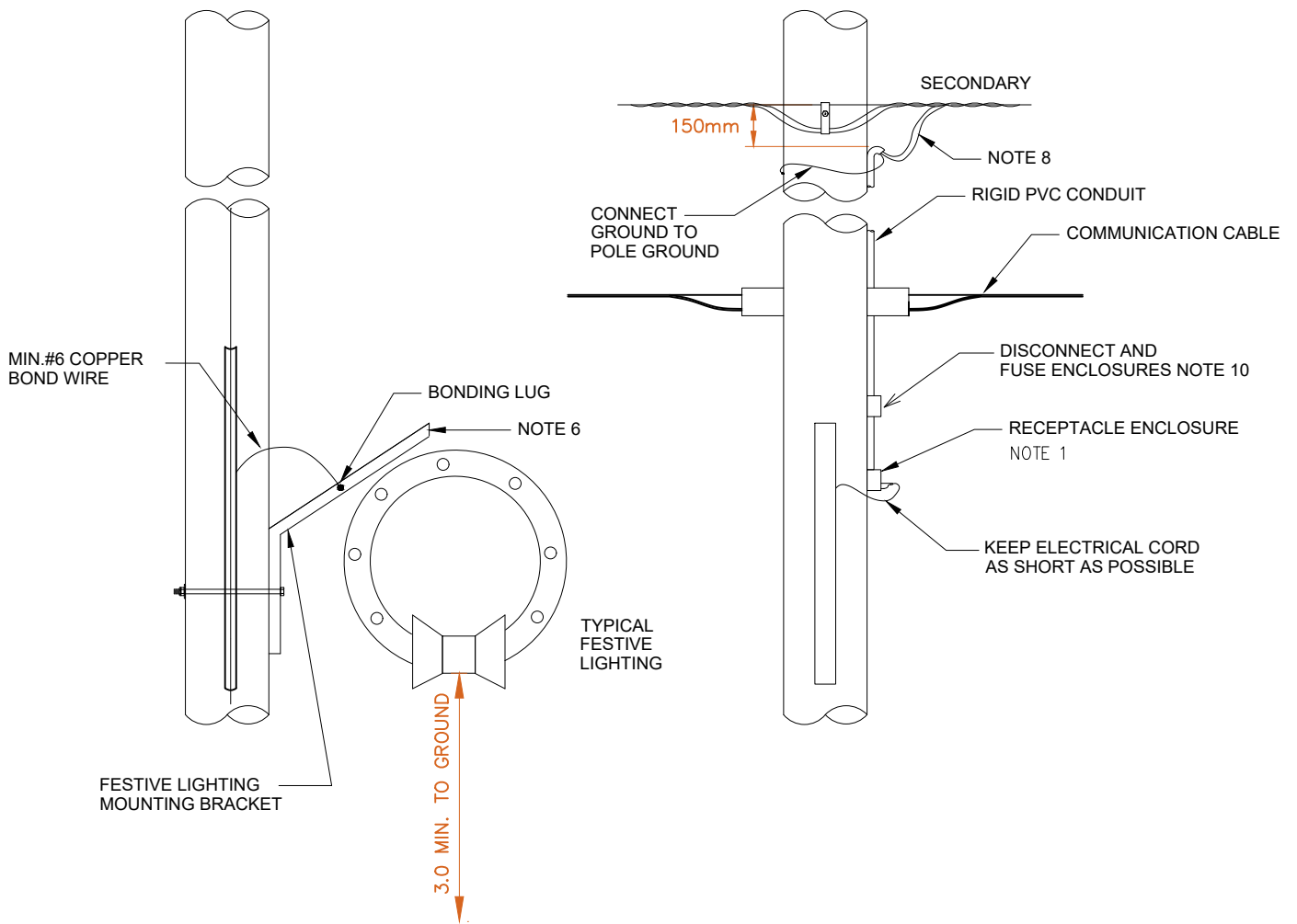

REVISION:	01	SUBJECT: <b>MUNICIPAL FESTIVE LIGHTING SUPPLIED DIRECTLY FROM NB POWER DISTRIBUTION SYSTEM</b>	E.D.:
EFF. DATE:	JAN 1999		<b>FIG.13</b>

**NOTES:**

1. RECEPTACLE TO BE INSTALLED IN A CSA CLASS 3 ENCLOSURE OR A WEATHERPROOF OUTLET BOX C/W PVC WEATHERPROOF COVER.
2. PLACE RIGID PVC CONDUIT AS FAR AWAY FROM TELEPHONE PLANT AND RECEPTACLE AS CLOSE TO LIGHTNING MOUNTING BRACKET AS IS PRACTICAL.
3. ENCLOSURES AND CONDUITS TO BE ASSEMBLED BY MUNICIPALITY FOR MOUNTING AND CONNECTION BY NB POWER.
4. WIRING PERMIT IS REQUIRED.
5. #10 AWG COPPER CONDUCTORS TO SUPPLY RECEPTACLES.
6. WHERE MOUNTING BRACKET IS MADE OF CONDUCTIVE MATERIAL IT SHALL BE BONDED TO UTILITY POLE GROUND.
7. A  $\frac{1}{4}$ " DRAIN HOLE SHALL BE INSTALLED IN THE BOTTOM OF THE PVC OUTLET BOX.
8. 750mm OF WIRE TO BE PROVIDED FOR CONNECTION TO SECONDARY. ADDITIONAL 300mm REQUIRED WHERE OPEN WIRE SECONDARY EXISTS.
9. RECEPTACLES FOR SUPPLY OF POLE MOUNTED FESTIVE LIGHTING ONLY. EXTENSION CORDS ARE NOT TO BE USED TO SUPPLY LOADS AT GROUND LEVEL.
10. DISCONNECTING MEANS SHALL BE INTEGRAL OR ADJACENT TO FUSE. MAXIMUM 30A FUSE. FUSE TO BE CLASS J TYPE.