

Net Metering Program Application Package



Énergie NB Power

the power of possibility
débordant d'énergie

Introduction

Thank you for your interest in NB Power's Net Metering program. Net metering allows customers to generate electricity to offset their consumption, while remaining connected to our distribution system.

This package is meant to help you better understand our program and to provide you with some guidance in completing the application. It includes:

- an overview of the application process
- details on the net metering eligibility requirements
- a Net Metering Applicant Enrollment Process Checklist
- the Net Metering Interconnection Application with Terms and Conditions (Terms and Conditions must be read before completing the application)
- A sample of a Net Metering Interconnection Application, One Line Diagram, Site Location Map and Technical Specifications
- a list of additional resources that may be helpful with your application

If you have other questions or concerns about your application, please feel free to contact us at energyinquiries@nbpower.com. You can also visit our website for a list of Frequently Asked Questions on the program.

Thank you again for your interest, we wish you much success with your application.

Sincerely,

Sarah Kane
Product Development
NB Power

The Process

Please see eligibility criteria on the website and the following page.

Review the Terms and Conditions

The Terms and Conditions explain the rules under which NB Power and the customer must adhere to through the duration of the customer's enrollment in the program. It's very important that you read and understand it all before proceeding. Our team is ready to answer any questions you may have. You are invited to obtain legal advice before signing. The Terms and Conditions are non-negotiable which ensures fairness among all customers within the program.

Submit a signed Net Metering Application with Terms and Conditions

The Net Metering Interconnection Application form needs to be filled out with the correct customer and equipment information that will be used in the installation. It requires system technical knowledge. The customer should seek help from the installer and/or electrical contractor to fill out this form. All equipment and site location is to be reviewed and approved by NB Power before the system is installed. The customer is required to sign the Application Form. If you receive a rejected application letter, we will advise on what's missing or not eligible for equipment.

NB Power also requires the following information to be included in the application:

- One Line Diagram
- Site Location Map –Indicating the parcel of land and where the generation system will be located
- Manufacturer's Technical Specification of the equipment including the inverter

See **Appendix A** for an example of the Net Metering Interconnection Application.

The Terms and Conditions need to be signed by both NB Power Account Holders if this is the case.

Install system and get it approved by an Electrical Inspector

The Authority for electrical installations in New-Brunswick is the New Brunswick Department of Public Safety –Technical Inspection Services. The rules in place are that the Electrical Inspector needs to inspect and approve all renewable energy installations in NB. NB Power will need a written note from the Electrical Inspector approving the installation before we finalize net metering enrollment. This part of the process is done through a licensed Electrical Contractor.

Installation of the bi-directional meter

The meter will likely need to be replaced with one that can account for the energy sent back to the grid. It's important that the renewable energy system is not turned on before a bi-directional meter is installed. Most standard meters used today cannot account for the energy sent back to the grid. We will be notified by the field crew when the bi-directional meter is installed through our work management system.

Welcome to net metering!

Once the bi-directional meter is installed, we will finish up the administrative part of net metering and notify you by email when this has been completed.

Eligibility Requirements

The NB Power Net Metering program provides customers with the option to connect their own environmentally sustainable generation unit to NB Power's distribution system. The program allows customers to generate their own electricity to offset their consumption, while remaining connected to NB Power's distribution system. This is so they can meet their electricity demands when their generation unit cannot.

In order to qualify for the program, the generation units must:

- Not exceed 100 kW in Nameplate Capacity
- Come from renewable energy sources as prescribed in the provincial government's Electricity from Renewable Resources Regulation 2015-60. Sources like solar, wind and hydro are acceptable. If you have another source, please read though the regulation at: <http://laws.gnb.ca/en/ShowTdm/cr/2015-60/>
- Use equipment certified for use in the Province of New Brunswick. Please refer to the Interconnection Specifications (page 5) for further details.
- Have an Electrical Wiring Permit from a licensed electrician, and be inspected and approved by the New Brunswick Department of Public Safety, Technical Inspection Services. The applicant's electrical contractor should inquire as to what is needed before starting the project.
- A special type of meter will be installed replacing your existing meter. This new meter provides readings for the electricity you use from NB Power, and the excess electricity backfed to NB Power's distribution system. The generator cannot be turned on before metering is in place, and written approval from NB power is provided.
- It is also mandated by regulation that the owner of the home or place of business meets the ownership requirements below:

Local Ownership

- The generation must follow local ownership requirements as per the Electricity from Renewable Resources Regulation 2015-60.

Interconnection Specifications

Introduction

This document establishes technical specifications for the connection of net metered generation to NB Power's secondary distribution system.

The requirements outlined in this document do not constitute a complete design or installation specification.

The Applicant shall discuss the proposed project with NB Power prior to any purchase or installation of equipment.

NB Power Policy on Net-Metered Generation

Details about NB Power's Net Metering Program and the qualification requirements can be found at:

<https://www.nbpower.com/en/products-services/net-metering/>

General Information

NB Power's review of any proposal - its design, protection philosophy, and choice of devices and equipment - shall not be construed as confirming or endorsing the design. Nor is any warranty of safety, durability or reliability implied. NB Power shall not, by reason of such review or failure to review, be responsible for the adequacy of the design. The Applicant must agree to change interconnection equipment or protective devices as may be reasonably required by NB Power to meet the changing requirements of NB Power's system.

The installation shall meet the requirements of the Canadian Electrical Code and the New Brunswick Electrical Installation and Inspection Act. In New Brunswick, the Code and the Act, including wiring permits, plan approvals and inspections, are under the jurisdiction of the NB Department of Public Safety, Technical Inspection Services.

Nominal Voltage Levels and Variation Limits

NB Power adopts Canadian Standards Association (CSA) Standard CAN3 C235-83 – "Preferred Voltage Levels for AC Systems 0 to 50,000V" and its "Recommended Voltage Variation Limits". NB Power's nominal secondary system voltages are 120/240V single phase, and 120/208V and 347/600V three phase.

Equipment Certification

Electrical installation and construction is governed by the New Brunswick Electrical Installation and Inspection Act. The Act is enforced by the Inspection Authority - NB Department of Public Safety, Technical Inspection Services. Under the Act, all electrical equipment must be approved by a certification organization recognized by Technical Inspection Services (examples - CSA and ULc).

Inverter Based Systems

As per the Net Metering Interconnection Application (section “Additional Information”, item 3) the Applicant shall submit manufacturer’s literature describing the inverter type, its protection system and the operating thresholds for each abnormal system condition.

Grid-dependent inverters meeting the “Anti-Islanding Protection” certification requirements of UL1741/IEEE1547 or CSA C22.2 No. 107.1 do not require additional protection.

Inverters which are grid-independent shall require passive protection which typically includes sensing of the following conditions - over and under-voltage, over and under-frequency, and loss of utility-supply.

Inverter output shall be a sinusoidal waveform (a.k.a. true sine wave).

Disconnecting Means

Disconnecting devices must be approved by the NB Department of Public Safety, Technical Inspection Services, and meet the requirements of section 84 of the Canadian Electrical Code.

NB Power does not require a disconnect switch for generation connected at or below 600V via a certified grid-dependent inverter.

Review by NB Power and Permission to Connect

The Applicant or his agent shall submit a completed Net Metering Interconnection Application.

NB Power will review only the portion of the design which requires conformance to NB Power’s Net Metering Program.

Interconnected operation of the generator shall not commence until NB Power has granted permission by way of a letter of approval. NB power will not be making any adjustments to bills in the event that the customer does start generating energy before approval.

NB Power reserves the right to witness any part of the work, including, but not limited to, acceptance tests, commissioning tests, trip tests and the initial unit synchronization.

NB power reserves the right to immediately and without notice terminate the Net Metering Terms and Conditions if the customer starts their generator before receiving written approval and/or makes modifications or changes to their system without receiving prior approval.

Operating Requirements

The interconnection of privately-owned generation shall not adversely affect the distribution system nor deteriorate the quality of electrical service provided to other Customers.

Poor voltage regulation, harmonic voltage distortion, or transient voltages cannot be permitted and could result in disconnection. Mitigation and correction of operational problems is solely the responsibility of the generator Owner.

Net Metering Interconnection Application

APPLICANT

Are you: <input type="checkbox"/> Building a new home or business <input type="checkbox"/> Moving into an existing Net Metering site <input type="checkbox"/> Adding to existing system <input type="checkbox"/> Installing a new system on an existing account	Are you: (select one) <input type="checkbox"/> The legal property owner <input type="checkbox"/> The legal tenant <input type="checkbox"/> An authorized person with signing authority	NB Power Account Number where generator will be located:
--	--	--

Main Account Holder Name (Customer):	
Net Metering Site Address:	
Daytime Phone Number:	Email:

CONTRACTORS

	System Designer	Electrical Contractor
Company		
Name of Person Responsible		
Daytime Phone Number		
Email		

GENERATOR(S)

Source: Solar <input type="checkbox"/> Wind <input type="checkbox"/> Other <input type="checkbox"/>	If other, please specify:
Manufacturer:	Model Number:
Nameplate capacity for each panel or generator: W <input type="checkbox"/> kW <input type="checkbox"/>	Total number of panels or generators:
Total Capacity of Generator System (kW):	
IF SOLAR Roof Mount <input type="checkbox"/> Ground Mount <input type="checkbox"/>	Bifacial Modules:(if yes, include potential gain in capacity) Yes <input type="checkbox"/> No <input type="checkbox"/>
Solar Array Pointing: South <input type="checkbox"/> South West <input type="checkbox"/> South East <input type="checkbox"/> West <input type="checkbox"/>	If other please specify:
Pitch angle of array (horizontal =0 Deg) Deg Tracking System: Yes <input type="checkbox"/> No <input type="checkbox"/>	Tracking System Type: Vertical <input type="checkbox"/> Horizontal <input type="checkbox"/> Dual Axis <input type="checkbox"/>

INVERTER(S)

Manufacturer:	Model Number:
Rated Capacity for each Inverter: (AC) W <input type="checkbox"/> kW <input type="checkbox"/>	Inverter Count:
Total Inverter Capacity for System: (AC) W <input type="checkbox"/> kW <input type="checkbox"/>	Battery Storage: Yes <input type="checkbox"/> No <input type="checkbox"/>

REQUIRED ADDITIONAL INFORMATION (please enclose one copy of each)

<input type="checkbox"/> One Line Diagram – Showing entire generation system with inverters, breakers, transformers, and load equipment
<input type="checkbox"/> Site Location Map – Includes topographical details of structures, buildings, NB Power lines, easements, and generator location
<input type="checkbox"/> Manufacturer Technical Information – for the inverter, generator, batteries, and tracking system

DECLARATION (Please read carefully and agree by signing)

Please read, understand and accept including the Terms and Conditions attached hereto.

The included information is accurate in all details and I understand that I require NB Power approval prior to installing equipment. Connection of the equipment CANNOT be made until I receive written approval from NB Power, and a successful inspection has been completed and approved by the New Brunswick Department of Public Safety. If any changes whatsoever are made to the system beyond the capacity of the inverters in this application, I will re-submit an application to NB Power for approval.

I/We confirm that I/We (1) are the registered owner(s) of the premises, (2) have an understanding of how the equipment operates, (3) will be given a safety orientation to the equipment by the installer, (4) have read and understand the Terms and Conditions and have had the opportunity to obtain legal advice with respect to it; and (5) agree that the terms and conditions herein are part of the agreement, and will conform to the said terms and conditions.

Main Account Holder Name OR Authorized Person (Please Print)	Joint Customer Name (if applicable) (Please Print)
Main Account Holder / Authorized Person Signature	Joint Customer Signature
Date:	Reviewed by:
Approved Date:	Date letter sent to customer:

TERMS AND CONDITIONS (STANDARD AND FARMS)

Application

1. The Customer has completed NB Power's Net Metering Interconnection Application (the "Application") attached hereto.
2. The Customer's completed Application including location and details on the Customer owned electrical generation unit including any equipment or devices related to the generation of electricity and interconnection equipment (hereinafter called "Generation Unit(s)") are hereby incorporated into these Terms and Conditions as fully as if it were set forth herein.
3. The Customer certifies that it owns the facilities, Generation Unit(s), and is the NB Power Customer where kilowatt hour energy credits will be applied.
4. The Customer has identified in the Application that the facility where the Generation Unit(s) will be installed, operated and interconnected is owned and not leased.

Customer's Generation Unit(s)

5. The Customer's Generation Unit(s) shall be owned and operated by the Customer and all costs associated with the Customer's Generation Unit(s) shall be borne by the Customer.
6. The Customer's Generation Unit(s) shall be located on the Customer's premises, on the Customer's side of the utility meter on an account with active customer load. It shall include equipment necessary to meet all requirements established by New Brunswick Department of Public Safety, applicable CSA standards, NB Power's Rate Schedules and Policies Manual, and/or any amendments thereto, specifications set out in Section 10 hereafter and any and all applicable laws, codes and standards over and above those cited in this provision.
7. The Customer's Generation Unit(s) shall have a name plate rating of not more than 100 kW. The Customer shall ensure that electricity that is generated is and remains in compliance with New Brunswick Regulation 2015-60 Electricity from Renewable Resources Regulation-*Electricity Act*.
8. The Customer acknowledges and agrees that no connection on NB Power facilities will be allowed.
9. The Customer understands that the installation and/or operation of other equipment including, but not limited to a transfer switch or Generlink (with or without SureConnect service) to the meter(s) can increase the potential risk for damage to its Generation Unit(s), the other equipment, the transfer switch, or Generlink (with or without SureConnect service), and further acknowledges and agrees that any damage, losses or costs resulting therefrom, shall be the sole responsibility of the Customer.
10. The Customer shall comply with the technical requirements for connection as set out in NB Power's "Technical Specification for Net Metered Generation" which are amended from time to time, and to any successor document (the "Technical Specifications").
11. For Farms (as defined in NB Power's Rates Schedules and Policies manual) applying kilowatt hour energy credits to more than one metering point, NB Power in consultation with the Customer will determine which metering point the Generation Unit(s) will be physically connected.
12. NB Power shall have the sole authority to determine which interconnection requirements set forth herein are applicable to the Customer's Generation Unit(s).

Metering

13. NB Power shall supply, at its cost, and shall own and maintain all the necessary meters and associated equipment used for billing.
14. The Customer shall supply, at its cost, a safe and suitable location and safe and suitable access to NB Power for metering.
15. Net Metering will only commence when all metering locations have been approved by NB Power. NB Power shall reserve the right to remove or modify any metering location once Net Metering has commenced.

Maintenance and Permits

16. The Customer shall (i) maintain the Generation Unit(s) and interconnection facilities in a safe and prudent manner and in conformance with all applicable laws and regulations including, but not limited to, NB Power's Interconnection requirements; (ii) obtain any governmental authorizations and permits required for the construction and operation of its Generation Unit(s) and interconnection facilities, including electrical permit; (iii) reimburse NB Power for any and all losses, damages, claims, penalties, or liability it incurs as a result of Customer's failure to obtain or maintain any governmental authorizations and permits required for construction and operation of Customer's Generation Unit(s) or failure to maintain Customer's facility as required in this Section, and all such obligations shall survive the termination of these Terms and Conditions.
17. Approval of the Application attached hereto extends to future increases in generating capacity up to but not exceeding the rating of the inverter(s) proposed in the Application.
18. In the event the Customer wishes to add capacity to the Generation Unit(s) in excess of that which was approved by NB Power in the Application, up to the rating of the inverter, is subject to the prior approval of New Brunswick Department of Public Safety, Technical Inspection Services.

Main Account Holder OR Authorized Person Initial	Joint Customer Initial
---	------------------------

Operation

- 19. Once in operation, the Customer shall make no changes or modifications to the Generation Unit(s), wiring or the mode of operation without the prior written approval of NB Power.
- 20. Approval by NB Power of the Application extends to future increases in generating capacity up to but not exceeding the rating of the inverter(s) proposed in the Application.
- 21. Approval of an Application for a farm to apply kilowatt hour energy credits toward more than one metering point will require that the Customer maintain registered farm status with the Province of New Brunswick.
- 22. Any addition of capacity to the Generation Unit(s) as approved by NB Power under the Application, up to the rating of the inverter, is subject to the Customer obtaining the approval of New Brunswick Department of Public Safety, Technical Inspection Services.

Access To Premises

- 23. NB Power may enter the Customer's facility, premises or property (i) to inspect without prior notice at all reasonable hours Customer's protective devices and to read the meter; and (ii) to disconnect the interconnection facilities at the NB Power's meter or transformer, without notice, if, in NB Power's opinion, a hazardous condition exists and such immediate action is necessary to protect persons, or NB Power's facilities, or property of others from damage or interference caused by Customer's Generation Unit(s), or lack of properly operating protective devices or inability to inspect the same. These rights and obligations shall survive termination of these Terms and Conditions.

Indemnity and Liability

- 24. The Customer agrees that it/shall be liable for and that it shall indemnify and hold harmless and release NB Power and its officers, directors, employees, agents, contractors, shareholders and affiliates from and against any and all losses, claims, damages, costs, demands fines, judgments, penalties, obligations, payments and liabilities, together with any costs and expenses (including without limitation legal fees and out-of-pocket expenses and investigation expenses) incurred in connection with any of the foregoing, resulting from, relating to or arising out of or in connection with: (i) any failure or abnormality in the operation of the Customer's Generating Unit or any related equipment including transfer switches or GenerLink devices (with or without SureConnect service); (ii) any failure of the Customer in complying with the standards, specifications, or requirements referenced in NB Power's interconnection requirements, which results in abnormal voltages or voltage fluctuations, abnormal changes in the harmonic content of the Generation Unit(s) output, single phasing, or any other abnormality related to the quantity or quality of the power produced by the Generation Unit(s); (iii) any failure of the Customer to duly perform or observe any obligation, term, provision, covenant, or condition hereunder to be performed or by or on behalf of the Customer, or (iv) any negligence or intentional misconduct of Customer related to operation of the Generation Unit(s) or any associated equipment or wiring. The foregoing liability and indemnity provisions shall survive the termination of these Terms and Conditions.
- 25. Each of the Parties identified as "Customer" in these Terms and Conditions shall be jointly and severally liable to NB Power for the performance of the obligations of the Customer under these Terms and Conditions.

Force Majeure

- 26. Suspension of Obligations. Neither Party shall be liable to the other for, or be considered to be in breach of or default under these Terms and Conditions because of, any failure or delay in performance by such Party under these Terms and Conditions to the extent such failure or delay is caused by or results from any such cause or condition which is beyond such Party's reasonable control, or which such Party is unable to prevent or overcome by exercise of reasonable diligence (any such cause or conditions, a "Force Majeure"), including breach of contract or failure of performance by any person providing services to NB Power.
- 27. Notice; Required Efforts to Resume Performance. Any Party claiming Force Majeure shall give the other Party maximum practicable advance notice of any failure or delay resulting from a Force Majeure, and shall use its reasonable best efforts to overcome the Force Majeure and to resume performance as soon as possible.
- 28. No Excuse of Payment Obligations. Notwithstanding any other provision of these Terms and Conditions, in no event shall a Force Majeure excuse a Party's failure or delay to pay any amounts due and owing to the other Party under or pursuant to these Terms and Conditions.

Interruption or Reduction of Deliveries

- 29. NB Power may require the Customer to interrupt or reduce deliveries of electricity as follows: (a) when necessary in order to construct, install, maintain, repair, replace, remove, investigate, or inspect any of its equipment or part of its system; or (b) if NB Power determines that curtailment, interruption, or reduction is necessary because of emergencies, or compliance with good electrical practices as determined by NB Power.
- 30. To the extent reasonably practicable, NB Power shall give the Customer notice of possible interruption or reduction of deliveries of electricity.

Billing

- 31. NB Power shall bill the Customer monthly for the non-kilowatt hour energy charges due under NB Power's Rate Schedules and Policies Manual, plus all outstanding amounts for net kilowatt hour energy consumption. If the Customer generates kilowatt hour energy credits during any month, such credits will be carried over from month to month and subtracted from amounts otherwise due the following month, with the exception that on March 31st of each year, all kilowatt hour energy credits shall be set to zero. Based on GST/HST legislation, the Customer is required to pay HST on their entire electricity requirement from NB Power and not the net amount.

Main Account Holder OR Authorized Person Initial	Joint Customer Initial
---	------------------------

32. For Farms applying kilowatt hour energy credits to more than one metering point, NB Power will apply energy credits only to additional metering points with the same rate category and on the same or adjacent property where the Generation Unit(s) will be located in the following order:
- I. To the metering point where the Generation Unit(s) is located.
 - II. To one or more metering points related to farm operations.
 - III. To the family home.

Term and Termination

33. This Agreement shall continue on a month-to-month basis. Either Party may terminate this Agreement for any reason upon 30 days notice in writing to the other Party. Upon such termination, the Customer shall, at its cost, safely render inoperable the Generation Unit(s), inclusive of isolating the Generation Unit(s), which obligations shall survive termination of these Terms and Conditions.
34. NB Power reserves the right to terminate these Terms and Conditions at any time without notice if the Customer fails to comply with the terms of these Terms and Conditions or if the Customer no longer meets the eligibility criteria under the Technical Specifications. The Customer shall advise NB Power immediately if the Customer ceases to meet the eligibility criteria. If these Terms and Conditions are terminated by NB Power for breach of these Terms and Conditions by Customer, the Customer shall be responsible for payment of all costs associated with such termination. NB Power reserves the right to terminate these Terms and Conditions at any time without notice if the

Customer:

- I. Fails to comply with these Terms and Conditions or no longer meets the eligibility criteria under the Technical Specifications;
- II. For Farms applying kilowatt hour energy credits to more than one metering point, fails to maintain registered farm status with the Province of New Brunswick; or
- III. Makes changes in facility ownership, Generation Unit(s) ownership, or ceases to be an NB Power Customer at any location where kilowatthour energy credits are applied.

The Customer shall advise NB Power immediately if it ceases to meet the eligibility criteria. If the Terms and Conditions are terminated by NB Power for breach by the Customer, NB Power reserves the right to zero out any remaining kilowatthour energy credits for the period during the breach. The Customer shall be responsible for the requirement to isolate the Generation Unit(s) upon any such termination and shall be responsible for any and all costs associated with such termination, which obligations shall survive the termination of these Terms and Conditions.

If these Terms and Conditions are terminated by either Party for any reason, the remaining kilowatthour energy credits shall be:

- I. if Customer is moving immediately to another location served by NB Power, any remaining kilowatthour energy credits shall be transferred to the new location, subject to the conditions in Section 30.
- II. if Customer ceases to be an NB Power Customer or moves to a location not served by NB Power, any remaining energy credits shall be set to zero.
- III. If NB Power terminates the Terms and Conditions other than for breach by the Customer, NB Power will credit any remaining kilowatthour energy credits to the Customer's account.

35. Upon termination of these Terms and Conditions for any reason, the Parties acknowledge and agree that NB Power shall have the right to disconnect service to the facility in the event that the Customer fails to isolate the Generation Unit(s). This right shall survive any termination of these Terms and Conditions.
36. If the Customer wishes to participate in net metering within 24 months of the termination, of these Terms and Conditions (unless such termination is not caused, directly or indirectly, by the fault, act or omission of the Customer), the Customer agrees to pay all NB Power's costs associated with entering into a new Terms and Conditions, including all equipment and installation costs.

Personnel and System Safety

37. If at any time NB Power determines that the continued operation of the Customer's facility or Generation Unit(s) may endanger any person, property or NB Power's distribution system, or have an adverse effect on the safety or power quality of other customers, NB Power shall have the right to disconnect either or both of the Customer's Generation Unit(s) or facility from NB Power's distribution system. The Customer's Generation Unit(s) or facility shall remain disconnected until such time as NB Power is satisfied that the endangering or power quality condition(s) have been corrected, and NB Power shall not be obligated to accept any energy from the Customer during such period. The Customer shall be responsible for and agrees to pay NB Power for all costs incurred by NB Power related to disconnection of the Customer's Generation Unit(s) and/or facility if such disconnection is caused, directly or indirectly, by the act or omission of the Customer, and such responsibility shall survive any termination of these Terms and Conditions.

Miscellaneous

38. Authorization. Each Party represents and warrants to the other Party that the execution, delivery and performance by it of these Terms and Conditions has been duly authorized by all necessary corporate and regulatory action on its part and that the execution, delivery and performance by it of these Terms and Conditions does not result in a breach, violation of, or conflict with the terms of any contracts or instruments to which it is a party.

Main Account Holder OR Authorized Person Initial	Joint Customer Initial
---	------------------------

39. Independent Contractors. The Parties are, and will at all times remain, independent contractors. These Terms and Conditions does not create, and will not be construed in any way as creating, the relationship of joint ventures, partners, associates, principal and agent or any similar or like relationship between the Parties which could give rise to joint and several liability.
40. Severability. If any term of these Terms and Conditions is held illegal or unenforceable by a court with jurisdiction over the Terms and Conditions, all other terms of these Terms and Conditions shall remain in full force, and the illegal or unenforceable provision shall be deemed struck. In the event that the stricken provision materially affects the rights, obligations or duties of either Party, the Parties shall substitute a provision by mutual agreement that preserves the original intent of the Parties as closely as possible under applicable law.
41. Counterparts. These Terms and Conditions may be executed in original or electronic counterparts, each of which when so executed shall be deemed to be an original, and such counterparts together shall constitute but one and the same instrument. Signatures delivered by facsimile, or other electronic transmission, shall be deemed for all purposes to be original counterparts of these Terms and Conditions.
42. Further Assurances. Each Party will, at any time and from time to time, do, execute, acknowledge and deliver or cause to be done, executed, acknowledged and delivered, all such further documents, assurances or things, and secure all necessary consents, as may be reasonably required for the more perfect observance and performance by the Parties of the terms of these Terms and Conditions.
43. No Third Party Beneficiaries. Except where otherwise provided, these Terms and Conditions are not made for the benefit of any person not a party to these Terms and Conditions, and no person other than the Parties or their respective successors and permitted assigns shall acquire or have any right, remedy or claim under or by virtue of these Terms and Conditions.
44. Notices. Any notice or other communication pursuant to these Terms and Conditions shall be in writing and shall be deemed to have been duly given (i) when personally delivered, (ii) on the fifth business day after being mailed by registered or certified mail, postage prepaid, or (iii) on the next business day following the date of transmission by electronic mail, to the following addresses:

If to the Customer:

Customer contact information in Customer Care System and/or attached application

If to NB Power:

NB Power Corporation
P.O. Box 2000
515 King Street
Fredericton NB
E3B 4X1
Attention: Customer Interaction Center (HO3)
Email: Netmetering@nbpower.com
With a copy to: nbpowerlegal@nbpower.com

45. Entire Agreement. These Terms and Conditions constitutes the entire agreement between the Parties. These Terms and Conditions supersedes all prior and contemporaneous agreements, understandings, negotiations and discussions, written or oral, of the Parties relating to any transaction contemplated by these Terms and Conditions. These Terms and Conditions may be amended in writing when executed by both Parties.
46. Waiver. Waiver of or failure to exercise any right or remedy hereunder by either Party shall not restrict or limit the future exercise of that right or remedy or the exercise of any right or remedy.
47. Assignment. The Customer shall not be entitled to assign all or any portion of its interest in these Terms and Conditions without the prior written consent of NB Power, which consent will not be unreasonably withheld. Any assignment of these Terms and Conditions does not relieve the assignor of any obligations under these Terms and Conditions.
48. Binding Effect. These Terms and Conditions shall enure to the benefit of and be binding upon the Parties hereto and their respective successors and permitted assigns.
49. Headings; Language. The section and subsection headings used in these Terms and Conditions are for reference and convenience only, and shall not affect in any way the meaning or interpretation of these Terms and Conditions. The Parties acknowledge that they have expressly required that these Terms and Conditions and all related documents be drafted in the English language. Les Parties reconnaissent avoir expressément exigé que le présent convention et tous les documents connexes soient rédigés en langue anglaise.

Please forward application to NB Power

- By Mail : Customer Service 3rd floor, PO Box 2000
515 King Street, Fredericton NB E3B 4X1
- By Email: energyinquiries@nbpower.com

Main Account Holder OR Authorized Person Initial	Joint Customer Initial
---	------------------------

Net Metering Application Process Checklist

Qualifications and Energy Source

- Qualifications for the program meet requirements described in Pages 4 through 6.
- Proposed system meets municipal, provincial, and federal regulations.

Application Submission

- Interconnection Application form filled out (Example in Appendix A)
- One Line Diagram (Example in Appendix B)
- Site Location map (Example in Appendix C)
- Technical Specification of inverter(s) and other equipment used in system (Example in Appendix D)
- Agree to Terms and Conditions by signing the Application Form and initializing each page of the Terms and Conditions.

Application Approval

- Approval letter received from NB Power.
- Proposed system meet Department of Public Safety`'s requirements (Permit required)
- The system **cannot be turned on** before written approval from NB Power is provided

Inspection

- *The Electrical Inspector has inspected and approved the installed system.

Metering & Billing –Starting generator

- Bi-directional meter installed by NB Power
- Billing started by NB Power
- Received notification email that Net Metered Billing has started
- The system can now be turned on! Congratulations you are now generating your own renewable electricity.**

Note: *-The Bi-directional meter will not be installed until Application Package has been approved, AND the Dept. of Public Safety has inspected and approved the installed system and has notified NB Power in writing.

Appendix A

Sample of Net Metering Interconnection Application

Net Metering Interconnection Application			 the power of possibility débordant d'énergie	
APPLICANT				
Are you: <input type="checkbox"/> Building a new home or business <input type="checkbox"/> Moving into an existing Net Metering site <input checked="" type="checkbox"/> Adding to existing system <input type="checkbox"/> Installing a new system on an existing account		Are you: <input checked="" type="checkbox"/> The legal property owner (select one) <input type="checkbox"/> The legal tenant <input type="checkbox"/> An authorized person with signing authority		NB Power Account Number where generator will be located: 1234567-8
Main Account Holder Name (Customer):		John Doe		
Net Metering Site Address:		123 Any Street, Anytown, A1A 1A1		
Daytime Phone Number: 123-4567		Email: anyemail@mailserver.mail		
CONTRACTORS				
	System Designer		Electrical Contractor	
Company	Solar Company Inc		Good Electrical Service	
Name of Person Responsible	John Lastname		Paul Lastname	
Daytime Phone Number	234-5678		345-6789	
Email	john@solarcompany.cc		paul@gooelectric.cc	
GENERATOR(S)				
Source: Solar <input checked="" type="checkbox"/> Wind <input type="checkbox"/> Other <input type="checkbox"/>			If other, please specify:	
Manufacturer: Stellar Solar			Model Number: Stel-240-1	
Nameplate capacity for each panel or generator: W <input type="checkbox"/> kW <input type="checkbox"/>			Total number of panels or generators: 20	
Total Capacity of Generator System (kW): 240 Watts				
IF SOLAR Roof Mount <input type="checkbox"/> Ground Mount <input checked="" type="checkbox"/>			Bifacial Modules:(if yes, include potential gain in capacity) Yes <input type="checkbox"/> No <input type="checkbox"/>	
Solar Array Pointing: South <input type="checkbox"/> South West <input checked="" type="checkbox"/> South East <input type="checkbox"/> West <input type="checkbox"/>			If other please specify:	
Pitch angle of array (horizontal =0 Deg)	Deg 45	Tracking System: Yes <input type="checkbox"/> No <input checked="" type="checkbox"/>	Tracking System Type: Vertical <input type="checkbox"/> Horizontal <input type="checkbox"/> Dual Axis <input type="checkbox"/>	
INVERTER(S)				
Manufacturer: Stellar Inverters			Model Number: Stel-Inv-300	
Rated Capacity for each Inverter: (AC) W <input type="checkbox"/> kW <input type="checkbox"/>			Inverter Count: 20	
Total Inverter Capacity for System: (AC) W <input type="checkbox"/> kW <input checked="" type="checkbox"/>			Battery Storage: Yes <input checked="" type="checkbox"/> No <input type="checkbox"/>	
REQUIRED ADDITIONAL INFORMATION (please enclose one copy of each)				
<input checked="" type="checkbox"/> One Line Diagram – Showing entire generation system with inverters, breakers, transformers, and load equipment				
<input checked="" type="checkbox"/> Site Location Map – Includes topographical details of structures, buildings, NB Power lines, easements, and generator location				
<input checked="" type="checkbox"/> Manufacturer Technical Information – for the inverter, generator, batteries, and tracking system				
DECLARATION (Please read carefully and agree by signing)				
Please read, understand and accept including the Terms and Conditions attached hereto.				
The included information is accurate in all details and I understand that I require NB Power approval prior to installing equipment. Connection of the equipment CANNOT be made until I receive written approval from NB Power, and a successful inspection has been completed and approved by the New Brunswick Department of Public Safety. If any changes whatsoever are made to the system beyond the capacity of the inverters in this application, I will re-submit an application to NB Power for approval.				
I/We confirm that I/We (1) are the registered owner(s) of the premises, (2) have an understanding of how the equipment operates, (3) will be given a safety orientation to the equipment by the installer, (4) have read and understand the Terms and Conditions and have had the opportunity to obtain legal advice with respect to it; and (5) agree that the terms and conditions herein are part of the agreement, and will conform to the said terms and conditions.				
Main Account Holder Name OR Authorized Person (Please Print)			Joint Customer Name (if applicable) (Please Print)	
John Doe			Jane Doe	
Main Account Holder / Authorized Person Signature			Joint Customer Signature	
<i>John Doe</i>			<i>Jane Doe</i>	
Date: 2022/09/12			Reviewed by:	
Approved Date:			Date letter sent to customer:	
Ver: 2022/02				
Net Metering Interconnection Application Page 1 of 5				

Appendix B

Sample of One-Line Diagram

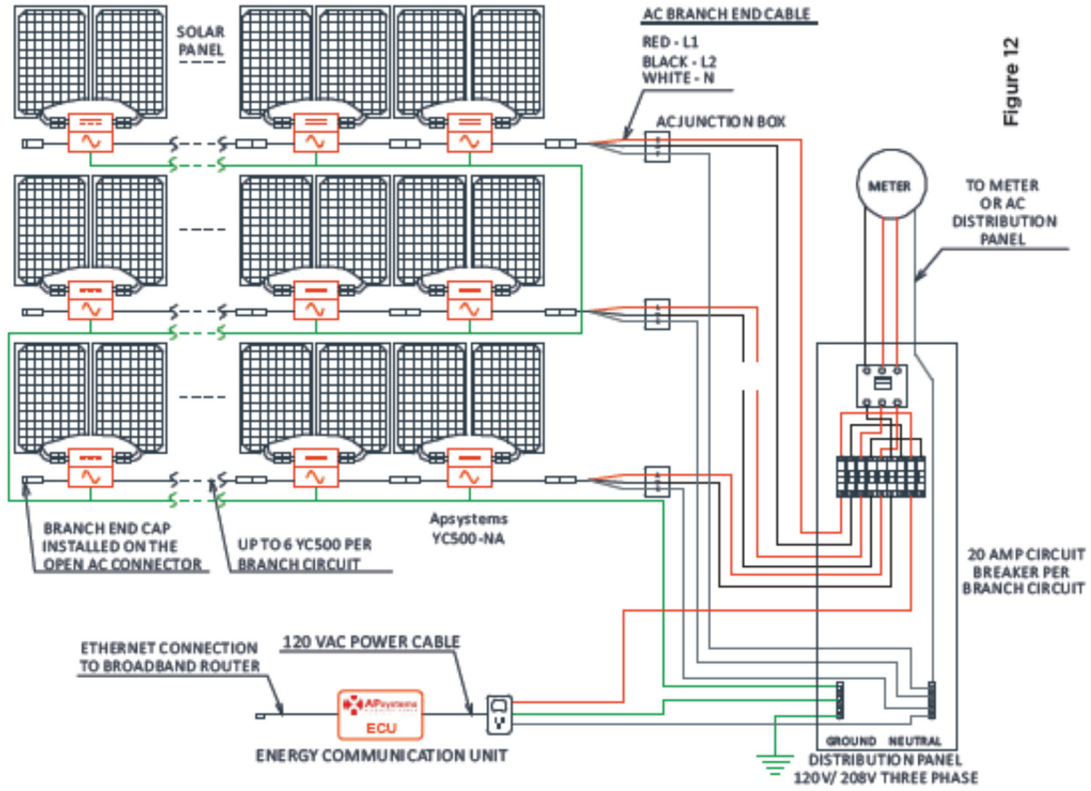

Figure 12

Appendix C

Sample of Site Location Map



Appendix D

Sample of Technical Specifications (part 1)

APsystems YC500A Microinverter Datasheet

INPUT DATA (DC)	
MPPT Voltage Range	22-45V
Maximum Input Voltage	55V
Maximum Input Current	12A X 2
OUTPUT DATA (AC)	
Rated Output Power	500W
Maximum Output Current	2.08A @ 240V 2.4A @208V
Nominal Output Voltage/Range - 240V	240V/211V-264V*
Nominal Output Voltage/Range - 208V	208V/183V-229V*
Nominal Output Frequency/Range	60Hz/ 59.3-60.5Hz***
Power Factor	>0.99
Total Harmonic Distortion	<3%
Maximum Units Per Branch	7 per 20A @ 240V 6 per 20A @ 208V
EFFICIENCY	
Peak Efficiency	95.5%
CEC Weighted Efficiency**	95%
Nominal MPP Tracking Efficiency	99.5%
MECHANICAL DATA	
Storage Temperature Range	-40°F to +185°F (-40°C to +85°C)
Operating Temperature Range	-40°F to +149°F (-40°C to +65°C)
Dimensions (WxHxD) inches	8.75" x 6.5" x 1.1"
Dimensions (WxHxD) mm	221mm x 167mm x 29mm
Weight	5.5 lbs (2.5kg)
Enclosure Rating	NEMA 6
Cooling	Natural Convection - No Fans
FEATURES & COMPLIANCE	
Communication	Power line (PLC)
Warranty	10 years standard, extendable to 25 years
Emissions & Immunity (EMC) Compliance	FCC PART 15, ANSI C63.4 2003, ICES-003
Safety & Grid Connection Compliance	IEEE1547, CSA C22.2 No. 1071-01, NEC 2014 690.12, NEC 2017 690.12 ***

*Default AC output is 240V mode. Programmable to 208V mode.

**CEC registered as Altenergy Power System Inc.

***Programmable per customer and utility requirements.

**** Meets the standard requirements for Distributed Energy Resources (UL 1741) and identified with the ETL Listed Mark.



Specifications subject to change without notice – please ensure you are using the most recent version found at APsystems.com

© 2017 All Rights Reserved

600 Erickson Ave NE, Suite 200, Seattle, WA 98110 | 844.666.7035 | APsystems.com



Appendix D

Sample of Technical Specifications (part 2)

MATRIX
AGM Line

INFINITY
Sealed Heavy Duty Motive Battery

MA-AG1002

Nominal Voltage	12V
Nominal Capacity(20HR)	100.0AH
Dimension	Length 307 ± 2mm (12.09 inches)
	Width 169 ± 2mm (6.66 inches)
	Container Height 211 ± 2mm (8.28 inches)
	Total Height (with Terminal) 215 ± 2mm (8.66 inches)
Approx Weight	Approx. 30.5 kg (67.2lbs)
Terminal	T3
Container Material	ABS
Rated Capacity	102.0 AH/1.12A (100hr, 1.80V/cell, 25°C/77°F)
	106.0 AH/5.00A (20hr, 1.80V/cell, 25°C/77°F)
	90.0 AH/9.00A (10hr, 1.80V/cell, 25°C/77°F)
	79.50 AH/15.9A (5hr, 1.75V/cell, 25°C/77°F)
	72.3 AH/24.10A (3hr, 1.75V/cell, 25°C/77°F)
55.4 AH/55.4A (1hr, 1.60V/cell, 25°C/77°F)	
Max. Discharge Current	1200A (5s)
Internal Resistance	Approx 5.0mΩ
Operating Temp. Range	Discharge : -20~55°C (-4~-131°F)
	Charge : 0~40°C (32~104°F)
	Storage : -20~-50°C (-4~-122°F)
Normal Operating Temp. Range	25 ± 3°C (77 ± 5°F)
Cycle Use	Initial Charging Current less than 28.0A Voltage
	14.4V-15.0V at 25°C(77°F)Temp. Coefficient -30mV/C
Standby Use	No limit on Initial Charging Current Voltage
	13.8V-13.8V at 25°C(77°F)Temp. Coefficient -20mV/C
Capacity affected by Temperature	40°C (104°F) 103%
	25°C (77°F) 100%
	0°C (32°F) 86%
Self Discharge	NPM series batteries may be stored for up to 10 months at 25°C(77°F) and then a refreshing charge is required. For higher temperatures the time interval will be shorter.



Voltage : 12 VOLTS

Capacity : 100AH @ 20hr



ISO9001 ISO14001

Constant Current Discharge (Amperes) at 25 C (77 F)

F. V/Time	5min	10min	15min	20min	30min	45min	1h	2h	3h	4h	5h	6h	8h	10h	20h
1.80V/cell	154.0	121.1	103.0	86.1	68.5	51.8	42.4	27.0	21.4	17.5	14.1	12.2	9.95	8.50	4.84
1.80V/cell	206.8	154.7	124.4	101.8	80.8	60.3	47.5	29.5	23.0	18.6	15.1	13.1	10.5	9.00	5.20
1.70V/cell	233.1	170.0	135.9	109.5	83.9	62.5	49.7	30.6	23.4	19.1	15.5	13.5	10.7	9.09	5.20
1.70V/cell	256.7	185.3	145.1	115.1	87.3	65.0	51.3	31.8	24.1	19.6	15.9	13.8	10.9	9.18	5.30
1.60V/cell	283.1	200.0	154.3	122.3	92.1	66.7	53.0	32.7	25.1	20.2	16.3	14.1	11.1	9.37	5.40
1.60V/cell	312.2	217.1	165.0	130.3	97.2	69.5	54.9	33.8	25.9	20.9	16.9	14.4	11.2	9.47	5.50

Constant Power Discharge (Watts/cell) at 25 C (77 F)

F. V/Time	5min	10min	15min	20min	30min	45min	1h	2h	3h	4h	5h	6h	8h	10h	20h
1.80V/cell	281.6	223.7	192.2	162.4	130.5	99.6	81.6	52.5	41.6	34.1	27.6	24.1	19.6	16.8	9.18
1.80V/cell	374.0	282.5	229.1	189.1	151.6	114.9	91.2	56.9	44.6	36.2	29.5	25.7	20.6	17.8	9.26
1.70V/cell	412.7	305.4	247.1	201.5	156.1	118.1	95.0	58.8	45.2	36.9	30.2	26.4	21.1	17.9	9.33
1.70V/cell	441.9	325.3	260.2	210.2	161.8	122.4	97.6	61.0	46.4	37.6	30.9	26.9	21.3	18.1	9.51
1.60V/cell	480.4	347.8	274.5	221.6	169.1	124.3	100.2	62.3	46.1	36.0	31.6	27.4	21.6	18.4	9.62
1.60V/cell	517.6	369.1	288.7	233.5	177.2	128.9	103.2	64.1	49.4	40.1	32.5	27.9	21.8	18.6	9.66

www.matrixinfinity.com SPEC 02 201707 15

Appendix D

Sample of Technical Specifications (part 3)

CS6P-220/225/230/235/240/245/250P

Electrical Data

	CS6P-220P	CS6P-225P	CS6P-230P	CS6P-235P	CS6P-240P	CS6P-245P	CS6P-250P
Nominal Maximum Power at STC (Pmax)	220W	225W	230W	235W	240W	245W	250W
Optimum Operating Voltage (Vmp)	29.2V	29.4V	29.8V	29.8V	29.9V	30.0V	30.1V
Optimum Operating Current (Imp)	7.53A	7.65A	7.78A	7.90A	8.03A	8.17A	8.30A
Open Circuit Voltage (Voc)	36.6V	36.7V	36.8V	36.9V	37.0V	37.1V	37.2V
Short Circuit Current (Isc)	8.09A	8.19A	8.34A	8.46A	8.59A	8.74A	8.87A
Operating Temperature	-40°C~+85°C						
Maximum System Voltage	1000V (IEC) /600V (UL)						
Maximum Series Fuse Rating	15A						
Power Tolerance	+5W						
Temperature Coefficient	Pmax	-0.43%/°C					
	Voc	-0.34 %/°C					
	Isc	0.065 %/°C					
	NOCT	45°C					

Under Standard Test Conditions (STC) of irradiance of 1000W/m², spectrum AM 1.5 and cell temperature of 25°C

Mechanical Data

Cell Type	Poly-crystalline
Cell Arrangement	60 (6 x 10)
Dimensions	1638 x 982 x 40mm (64.5 x 38.7 x 1.57in)
Weight	20kg (44.1 lbs)
Front Cover	Tempered glass
Frame Material	Anodized aluminium alloy
Standard Packaging (Modules per Pallet)	20pcs

Engineering Drawings

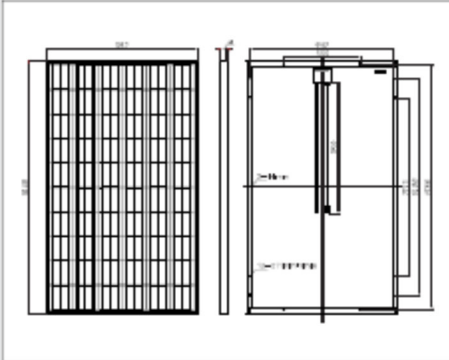

I-V Curves (CS6P-250P)

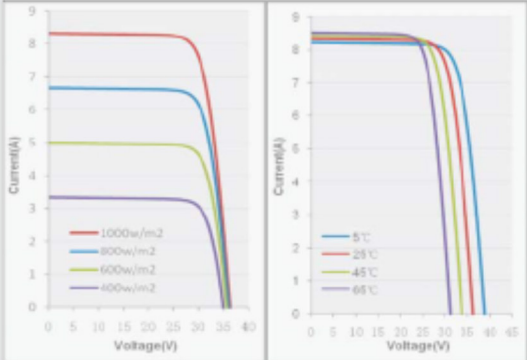

*Specifications included in this datasheet are subject to change without prior notice.

Appendix E

Additional Resources

NB Power's net metering website

<https://www.nbpower.com/en/products-services/net-metering/>

Renewables NB

<https://renewablesnb.ca/>

Department of Public Safety

https://www2.gnb.ca/content/gnb/en/departments/public-safety/law-enforcement-and-inspections/content/technical_inspection_services.html

Canadian Solar Industries Association

<http://www.cansia.ca/>

Canadian Wind Energy Association

<http://canwea.ca/>